

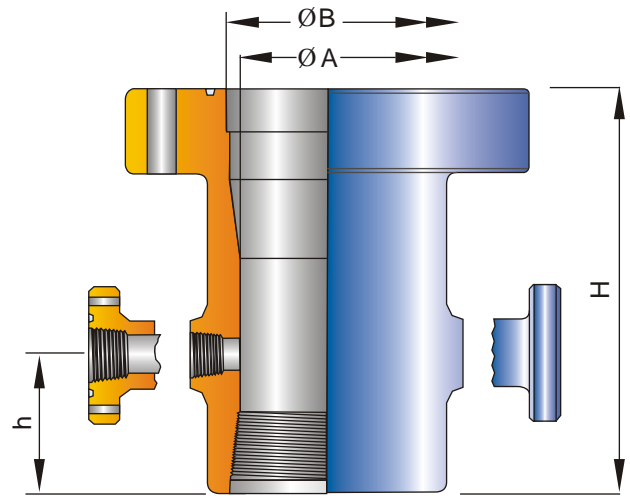

CASING HEAD

PARVEEN's 'PCH' Casing Head e.g. Casing Head Housing (PCHH) and Casing Head Spool (PCHS) accept Automatic Casing Hanger (PCHA), Unitised Casing Hanger (PCHU), S-Slips (PS) & S-Pack off (PSPO) assembly and can be furnished with female thread or slip-on weld lower connection. Standard outlets are 2" LINE PIPE threads or 2" API extended flanged with optional VR THREADS and end connection may be threaded or slip on weld type. Hold down screws to energize the annulus seal can be furnished on request.



Parveen Casing Head Housing (PCHH) Threaded Type

(Caution: Casing Hangers with attached seals which are not held down by hold down screws may be unseated when the annulus pressure multiplied by the annulus area exceeds the pipe load).

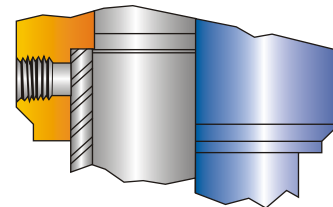

Slip-On Weld Conn

PARVEEN CASING HEAD HOUSING (PCHH) DIMENSIONS						
Rating	Top Flange Size	Casing Size	Total Height (H)	Height Of Side Outlets (h)	Thru Bore (Min A)	Bore Top Flange (B)
2000 PSI *	11	8 5/8	19	6 1/2	8 1/6	10 31/32
	11	9 5/8	19	6 1/2	9 1/8	10 31/32
	11	10 3/4	19	6 1/2	9 15/16	10 31/32
	13 5/8	11 3/4	19	6 1/2	9 15/16	10 31/32
	13 5/8	13 3/8	19	6 1/2	12 1/2	13 19/32
	16 3/4	16	18 1/8	6 1/2	15 3/8	16 11/16
	21 1/4	20	15 11/16	5	18 15/16	20 1/4
3000 PSI *	11	8 5/8	19	6 1/2	8 1/16	10 31/32
	11	9 5/8	19	6 1/2	9 1/8	10 31/32
	11	10 3/4	19	6 1/2	9 15/16	10 31/32
	13 5/8	11 3/4	19	6 1/2	11 3/8	13 19/32
	13 5/8	13 3/8	19	6 1/2	12 1/2	13 19/32
	16 3/4	16	18	6 1/2	15 3/8	16 11/16
	20 3/4	20	15 11/16	6 1/2	18 15/16	20 1/4
5000 PSI *	11	8 5/8	19	6 1/2	8 1/16	10 31/32
	11	9 5/8	19	6 1/2	9 1/8	10 31/32
	11	10 3/4	19	6 1/2	9 15/16	10 31/32
	13 5/8	13 3/8	19	6 1/2	12 1/2	13 19/32

NOTES:

- 1) All dimension are in inches.
- 2) Landing Bases are available with housings.
- 3) * Casing thread connection limits maximum working pressure rating (as per API-6A) to 5000 psi for 4 1/2" - 10 3/4" casing, to 3000 psi for 11 3/4" - 13 3/8" casing & to 2000 psi for 16" - 20" casing.



CASING HEAD SPOOL

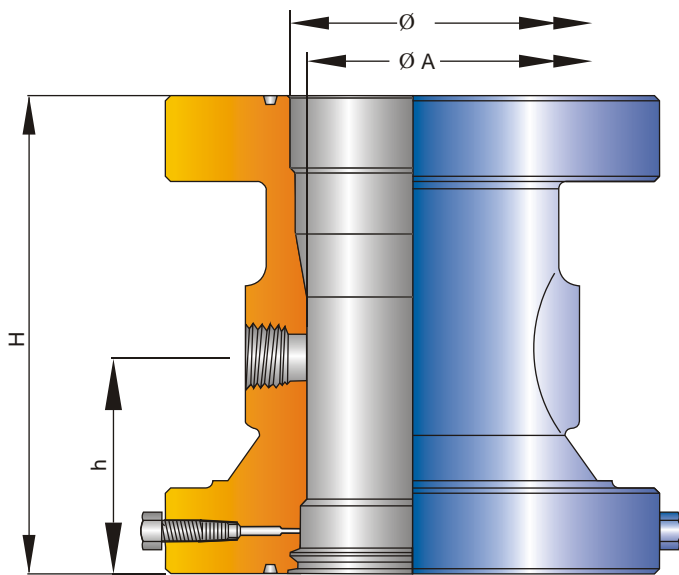

Parveen Casing Head Spool (PCHS)

PARVEEN's Casing Head Spool (PCHS) accepts automatic (PCHA) and unitised (PCHU) casing hangers. Standard outlets are 2 1/16", 2000-10000 PSI WP. Studded or flanged outlets can also be furnished with threaded 2" Line pipe connection. Studded or flanged outlets have internal threads for valve removal plugs. Bottom of the flange is designed for installation on the bit guides and PARVEEN type PBP -1 & PBP - 2 bottom pack-off, CROSSOVER SEAL (PP Seal over 5000 PSI WP) and is provided with a plastic packing injection port with bleeder outlet and a test port. For high pressure (over 3000 PSI W.P) the type 'PSPO' pack-off is used at the top of the casing hanger to prevent collapse of the casing pipe. Hold down screws can be furnished on request.

PARVEEN CASING HEAD SPOOL (PCHS) DIMENSIONS					
Flange Sizes		Dimensions			
Bottom	Top	Overall Height(H)	Height Of Side Outlets (h)	Minimum Bore (A)	Top Flange Bore (B)
11 X 2000	11 X 2000	20 1/8	10 1/16	8	10 31/32
11 X 2000	11 X 3000	20 5/8	10 1/16	8	10 31/32
11 X 3000	11 X 3000	21	10 1/2	8	10 31/32
11 X 3000	11 X 5000	23 3/4	10 5/8	8	10 31/32
11 X 5000	11 X 5000	25 1/2	12 3/8	8	10 31/32
13 5/8 X 2000	11 X 2000	20 1/4	10 3/16	9 15/16	10 31/32
13 5/8 X 2000	11 X 3000	20 3/4	10 3/16	9 15/16	10 31/32
13 5/8 X 3000	11 X 3000	21 1/2	11	9 15/16	10 31/32
13 5/8 X 3000	11 X 5000	25 1/8	12	9 15/16	10 31/32
13 5/8 X 5000	11 X 10000	25 1/2	12 3/8	9 15/16	10 31/32
16 3/4 X 2000	11 X 2000	21 1/8	11 1/16	9 15/16	10 31/32
16 3/4 X 2000	11 X 3000	22 3/4	10 3/4	9 15/16	10 31/32
16 3/4 X 3000	11 X 3000	24 5/16	12 5/16	9 15/16	10 31/32
16 3/4 X 3000	11 X 5000	26	12 3/8	9 15/16	10 31/32
16 3/4 X 2000	13 5/8 X 2000	21 1/4	11 1/16	12 1/2	13 19/32
16 3/4 X 3000	13 5/8 X 3000	22 7/8	11 15/16	12 1/2	13 19/32
16 3/4 X 3000	13 5/8 X 5000	27 1/16	11 15/16	12 1/2	13 19/32
21 1/4 X 2000	13 5/8 X 2000	22 1/16	11 7/8	12 1/2	13 19/32

NOTE :

All Dimensions are in Inches.

CASING & TUBING HANGER

Automatic Casing, Hanger (PCHA) is basically designed for heavy load service and is used for PARVEEN's Casing Head Housing 'PCHH' and Casing Head Spool 'PCHS' described earlier. When the Casing load is applied to the hanger, the top ring connected by the Pack-off and shoulder screw compresses the packing to seal the annulus pressure of the casing. This casing hanger is normally used for pressure ratings up to 3000 PSI. For ratings over 3000 PSI, type 'PSPO' Pack-off is used to prevent collapse of the pipe.

Unitised Casing Hanger (PCHU) can be used both for PARVEEN's Casing Head Housing (PCHH) and Casing Head Spool (PCHS) as described earlier. This Hanger is designed for medium or heavy load service. This hanger is normally latched around the pipe and lowered in casing head body. After the casing is landed, shoulder screws should be evenly tightened to affect a positive annular seal. The hanger may be used up to 3000 PSI WP. For ratings over 3000 PSI, 'PSPO' Pack-off is used to prevent collapse of the pipe.

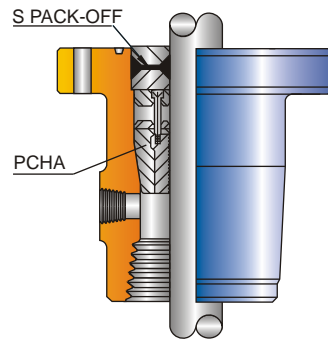

Type PCHA Automatic Casing Hanger with Slip Seal Assly

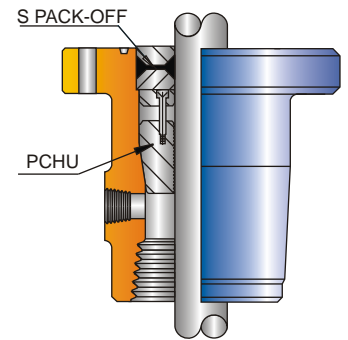

Type 'PCHU' Unitised Casing Hanger with Slip Seal Assly

Casing Hanger - PARVEEN Casing Hangers are basically 2 types, i.e. Automatic Casing Hanger (PCHA) and Unitised Casing Hanger (PCHU). S-Slips (PS) and S-Pack off (PSPO) assembly are also shown.

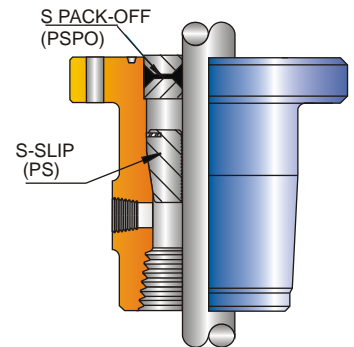

Type S-Slip (PS) Casing Hanger with S-Pack-off (PSPO) and S-Slip

SPECIFICATIONS OF PARVEEN'S CASING HANGER

Nominal Flange Size	Casing Size											
	4 1/2	5	5 1/2	6 5/8	7	7 5/8	8 5/8	9 5/8	10 3/4	11 3/4	13 3/8	16
9	PCHA PCHU	PCHU	PCHA PCHU									
11	PCHA PCHU	PCHA PCHU	PCHA PCHA	PCHA PCHU	PCHA PCHU	PCHA PCHU	PCHA					
13 5/8					PCHA PCHU	PCHA PCHU	PCHA PCHU	PCHA PCHU	PCHA			
16 3/4								PCHA PCHU	PCHA PCHU	PCHA	PCHU	
20 3/4 & 21 1/4											PCHA PCHU	

Nominal Flange Size	Casing Size											
	4 1/2	5	5 1/2	6 5/8	7	7 5/8	8 5/8	9 5/8	10 3/4	11 3/4	13 3/8	16
9	PS	PS	PS									
11	PS PSPO	PS PSPO	PS PSPO	PS PSPO	PS PSPO	PS PSPO	PS					
13 5/8			PS PSPO	PS PSPO	PS PSPO	PS PSPO	PS PSPO	PS PSPO	PS			
16 3/4								PS PSPO	PS PSPO		PS PSPO	
20 3/4 & 21 1/4									PS PSPO		PS PSPO	PS PSPO

PCHA: PARVEEN's Automatic Casing Hanger, **PS:** PARVEEN's S - Slip,

PCHU: PARVEEN's Unitised Casing Hanger, **PSPO:** PARVEEN's S - Pack-off.



CASING & TUBING HANGER

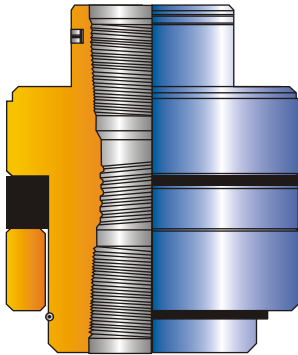

Type PTHSE
Extended Neck Hanger

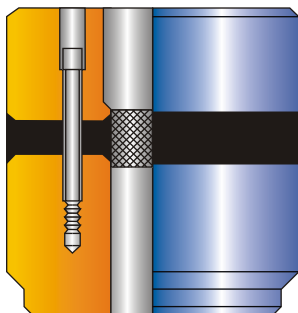

Type PTHSW
Wrap Around Hanger

Tubing Hangers - PARVEEN's Tubing Hangers are basically four types. These are Mandrel Type 'PTHSM', Wrap Around Type 'PTHSW', Extended Neck Type 'PTHSE' and Dual Split Type 'PTHDE'. Extended Neck Type with control lines 'PTHSCCL', Dual Split Type with control lines 'PTHDCCL', mandrel type with metal to metal seals (PTHTSM) and Mandrel type equipped with a continuous control line with metal to metal seals such as PTHTSMM are also supplied.

'PTHSM' type Tubing Hanger is used for the PTHS type of Tubing Head Spool described later. It seals the annulus pressure by compressing the seal with the weight of the tubing and the hold down screws.

Extended Neck Type 'PTHSE' is used for the Tubing Head/Spool described later. This type is like 'PTHSM' type tubing hanger but having an extended neck with a seal ring which seals fluid in the tubing. This type seals the annulus pressure by compressing the seal with the weight of the tubing and the hold down screws.

The 'PTHSW' type is a split type tubing hanger and may be wrapped round the tubing. It seals the annulus pressure by compressing the seal with the hold down screws installed in the top flanges of the spool. This type of hanger is used where tubing must be rotated or moved up and down under pressure. This tubing hanger is used together with a tubing hanger coupling and a tubing hanger spool.

Specifications of PTHSM & PTHSE Type Hangers					
Nominal Flange Size	Tubing Hanger Type	Lift & Suspension Threads			
		2 3/8 Up TBG	2 7/8 Up TBG	3 1/2 Up TBG	4 1/2 Up TBG
7 1/16	PTHSM	X	X	X	X
	PTHSE	X	X	X	X
9	PTHSM	X	X	X	X
	PTHSE	X	X	X	X
11	PTHSM	X	X	X	X
	PTHSE	X	X	X	X

NOTE:

- 1) X-API standard tubing threads.
- 2) These hangers can also be offered with premium threads at request.
- 3) All sizes are in inches.

CASING & TUBING HANGER

Dual split type Tubing Hanger 'PTHDE' is used for Dual Tubing String applications. This utilises plastic packing between the seals for sealing. It is fixed by hold down screws.

Dual split type tubing hangers can also be fitted with hydraulic control lines 1 or 2 called 'PTHDC1' & 'PTHDC2'.

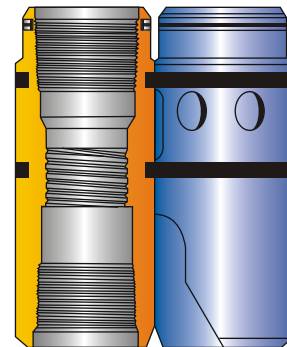

PTHDE Tubing Hanger

Specifications of 'PTHDE' Type Tubing Hangers				
Tubing Pipe	Bore Centre to Bore Centre	Nominal Flange Size	Casing Pipe	
			O.D.	Weight
1.90 x 1.90	2 25/32	7 1/16	5 1/2	17 LBS/FT
2 3/8 x 2 3/8	3 25/32	7 1/16	7	38 LBS/FT
2 7/8 x 2 3/8	3 35/64	7 1/16	7	29 LBS/FT
2 7/8 x 2 3/8	4	9	7 5/8	39 LBS/FT
2 7/8 x 2 7/8	4	9	7 5/8	29.7 LBS/FT
2 7/8 x 2 7/8	4 1/2	9	8 5/8	49 LBS/FT
3 1/2 x 2 7/8	5 3/64	11	9 5/8	53.5 LBS/FT
3 1/2 x 3 1/2	5 3/64	11	9 5/8	53.5 LBS/FT

NOTE: All dimensions are in Inches.

Extended Neck Type Tubing hangers are equipped with a control line (or lines) to control the opening and closing of sub-surface safety valves (SSSV) from the surface. These are called 'PTHSCL1' & 'PTHSCL2'.

The type 'PTHSCL1' is equipped with 1 (1/4") hydraulic control line while 'PTHSCL2' is equipped with 2 hydraulic control lines. Both these types seal the annulus pressure by compressing the seal with the hold down screws installed in the type 'PTHS' Tubing spool top flange.

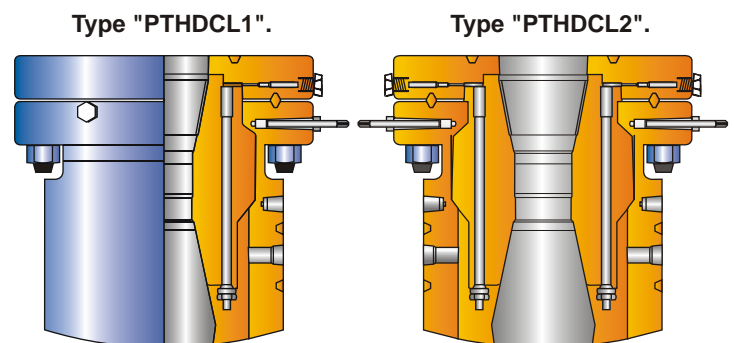

Extended Neck type Tubing Hangers

Specifications for 'PTHSCL & PTHDCL' Tubing Hangers					
Nominal Flange Size	Tubing Hanger Type	Lift & Suspension Threads			
		2 3/8 Up TBG	2 7/8 Up TBG	3 1/2 Up TBG	4 1/2 Up TBG
7 1/16	PTHSCL	X	X	X	
	PTHDCL	X	X		
9	PTHSCL	X	X	X	X
	PTHDCL	X	X	X	X
11	PTHSCL	X	X	X	X
	PTHDCL	X	X	X	X

NOTE:

- 1) X-API Standard Tubing Threads.
- 2) These hangers can also be offered with premium threads at request.
- 3) All sizes are in inches



CASING & TUBING HANGER

PARVEEN's Mandrel Type Tubing Hanger with metal to metal seals called 'PTHTSM' are used with PARVEEN's Tubing Spool and are equipped with metal to metal seal for fluids which prohibit the use of elastomer seals. These hangers have metal rings at the top and bottom for sealing. The rated working pressure range is 5000 psi to 15000 psi.

PARVEEN's PTHTSMM hangers fitted with single or dual hydraulic control lines are called PTHTSMM1 & PTHTSMM2. These are equipped with metal to metal seals for fluids prohibiting the use of elastomeric seals. Sealing is affected by metal ring mounted on the top of the hanger and load applied to the bottom of the hanger body.

Tubing Head Adapters

PARVEEN's Tubing Head Adaptors are designed for tubing suspension and can be used with extended neck threaded hanger PTHSE for a max WP of 15000 PSI. These can be provided with a studded up connections and a recessed lower flange with test & bleed ports. Tubing Head Adaptors can also be used with wrap around tubing hanger (PTHSW) for a max. WP of 10000 PSI and are threaded female for tubing suspension. It can be threaded according to the customer specification.

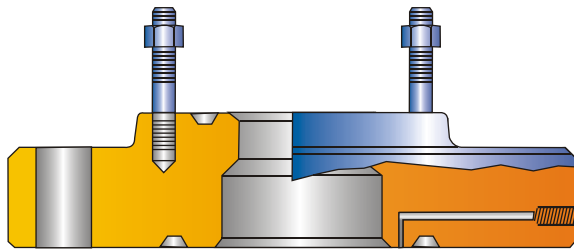

Type PTHSE Tubing Head Adaptor

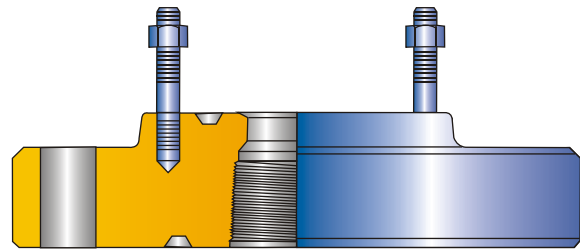

Type PTHSW Tubing Head Adaptor

Tubing Head Adaptors PTHSE Specifications		
Bottom Flange Size	Studded Top Flange	Min. Bore
7 1/16 x 2000	2 1/16 x 2000	2 1/16
	2 1/16 x 5000	2 1/16
	2 9/16 x 2000	2 9/16
	2 9/16 x 5000	2 9/16
	3 1/8 x 2000	3 1/8
	3 1/8 x 3000	3 1/8
7 1/16 x 3000	2 1/16 x 5000	2 1/16
	2 9/16 x 5000	2 9/16
	3 1/8 x 3000	3 1/8
	3 1/8 x 5000	3 1/8
7 1/16 x 5000	2 1/16 x 5000	2 1/16
	2 9/16 x 5000	2 9/16
	3 1/8 x 5000	3 1/8
7 1/16 x 10000	2 9/16 x 10000	2 9/16
	3 1/16 x 10000	3 1/16
7 1/16 x 15000	2 1/16 x 15000	2 1/16
	2 9/16 x 15000	2 9/16

Tubing Head Adaptors PTHSW Specifications			
Bottom Flange Size	Studded Top Flange	Thread Size API-Up TBG	Min. Bore.
7 1/16 x 2000	2 1/16 x 2000	2 3/8	2 1/16
	2 1/16 x 5000	2 3/8	2 1/16
	2 9/16 x 2000	2 7/8	2 9/16
	2 9/16 x 5000	2 7/8	2 9/16
	3 1/8 x 2000	3 1/2	3 1/8
	3 1/8 x 3000	3 1/2	3 1/8
7 1/16 x 3000	2 1/16 x 5000	2 3/8	2 1/16
	2 9/16 x 5000	2 7/8	2 9/16
	3 1/8 x 3000	3 1/2	3 1/8
	3 1/8 x 5000	3 1/2	3 1/8
7 1/16 x 5000	2 1/16 x 5000	2 3/8	2 1/16
	2 9/16 x 5000	2 7/8	2 9/16
	3 1/8 x 5000	3 1/2	3 1/8
7 1/16 x 10000	2 9/16 x 10000	2 7/8	2 9/16

NOTE:

- 1) Other sizes available on request.
- 2) All Dimensions are in inches.



TUBING HANGER SPOOL & COUPLING

PARVEEN also manufactures **Tubing Hanger Spools** and **Tubing Hanger Couplings**. Tubing Hanger Spool is used in combination with Tubing Hanger coupling, Wrap around tubing hanger (PTHSW) and 'PTHS' type tubing spool. Tubing Hanger Coupling allows installation by screwing the union nut of the tubing hanger coupling without a need to turn the X-mas tree. Coupling is threaded for installing a back pressure valve. Top & Bottom of the coupling can be threaded to suit customer's requirement.

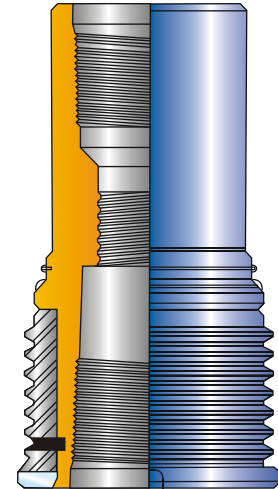

Tubing Hanger Coupling

SPECIFICATIONS OF TUBING HANGER COUPLING			
Size			
4 1/2 x 2 3/8	API	UPSET	TUBING
4 1/2 x 2 7/8	API	UPSET	TUBING
6 5/16 x 3 1/2	API	UPSET	TUBING
6 7/8 x 4 1/2	API	UPSET	TUBING

SPECIFICATIONS OF TUBING HANGER SPOOL		
Bottom Flange x Studded Top Flange	Bore	Bottom Prep
7 1/16 2000 x 2 9/16 2000	2 9/16	4 1/2
7 1/16 3000 x 2 1/16 5000	2 1/16	4 1/2
7 1/16 3000 x 2 9/16 5000	2 9/16	4 1/2
7 1/16 5000 x 2 1/16 5000	2 1/16	4 1/2
7 1/16 5000 x 2 9/16 5000	2 9/16	4 1/2
7 1/16 5000 x 3 1/8 5000	3 1/8	6 5/16
7 1/16 5000 x 4 1/16 5000	4 1/8	6 7/8
9 5000 x 2 1/16 5000	2 1/16	4 1/2
9 5000 x 3 1/8 5000	3 1/8	6 5/16
9 5000 x 4 1/16 5000	4 1/8	6 7/8
11 5000 x 2 9/16 5000	2 9/16	4 1/2
7 1/16 10000 x 2 1/16 10000	2 1/16	4 1/2
7 1/16 10000 x 2 9/16 10000	2 9/16	4 1/2
7 1/16 10000 x 3 1/16 10000	3 1/16	6 5/16
9 10000 x 4 1/16 10000	4 1/16	6 7/8
7 1/16 15000 x 1 13/16 15000	1 13/16	4 1/2
7 1/16 15000 x 2 1/16 15000	2 1/16	4 1/2
7 1/16 15000 x 2 9/16 15000	2 9/16	4 1/2

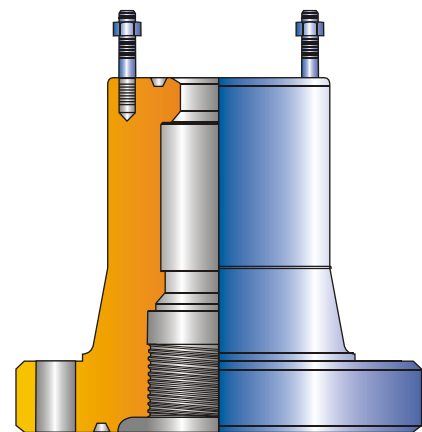

Tubing Hanger Spool

NOTE :

All dimensions are in inches



BOTTOM PACK-OFF CROSS OVER SEAL

The standard **bottom pack - off** is type '**PBP1**'

The bottom pack - off is installed in the lower flange of the casing head spool and tubing head spool to prevent the lower flange from being exposed to high pressure.

The bottom pack-off type 'PBP1' seals the annulus pressure by injecting packing. The bottom pack - off PBP - 2 is designed to give a positive annular seal with pressure energized oversize O - Rings.

For services at working pressures above 5,000 psi, the 'PP' seal is used.

When the bottom pack - off is used, the casing should be cut 90 mm from the top flange surface of the connecting spool.

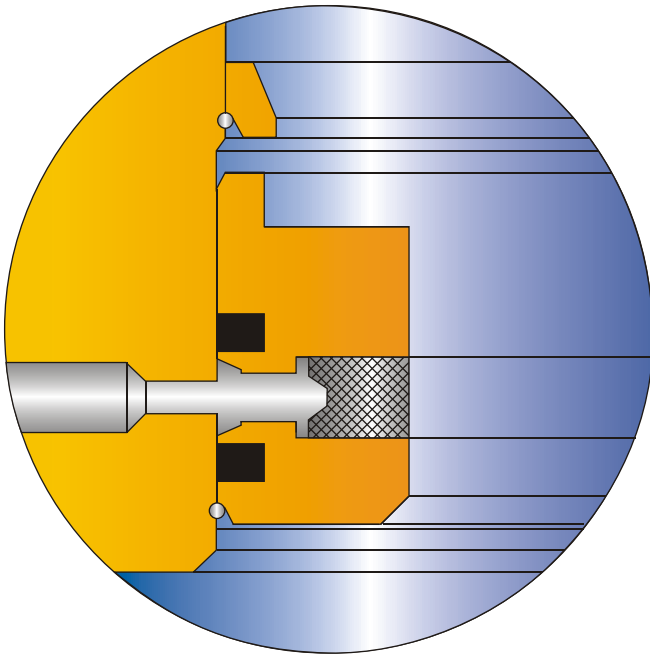

Bottom Pack-OFF (PBP-1)

Nominal Flange Size	Casing Pipe										
	4 1/2	5	5 1/2	6 5/8	7	7 5/8	8 5/8	9 5/8	10 3/4	11 3/4	13 3/8
9	O	O	O								
11	O	O	O	O	O	*					
13 5/8			O	O	O	O	O	O			
16 3/4								O	O	O	
20 3/4 & 21 1/4								O	O	O	

O Type 'PBP-1', * Type 'PBP-2'

NOTE:

All sizes are in inches



TUBING HEAD

PARVEEN's Tubing Head Spools (PTHS) body have a straight bore with a 45 deg landing shoulder. While the top flange has hold down screws as standard equipment for securing tubing hanger, the bottom flange is designed for installation of PARVEEN's bottom pack - off PBP-1 & PBP - 2 (PP-seal for high pressure over 5000 PSI) and is provided with bit guide, a plastic packing injection port with bleeder outlet and a test port. This can accept Tubing Hangers Mandrel Type 'PTHSM', Wrap around type 'PTHSW' and Extended neck type 'PTHSE'.

Standard outlets are 2 1/16" 2000 -10000 PSI WP studded. Even 2" Line Pipe & Flanged outlets can also be provided. Studded outlets are threaded internally for the valve removal plugs. Top flange is provided with hold down screws to secure tubing hanger.

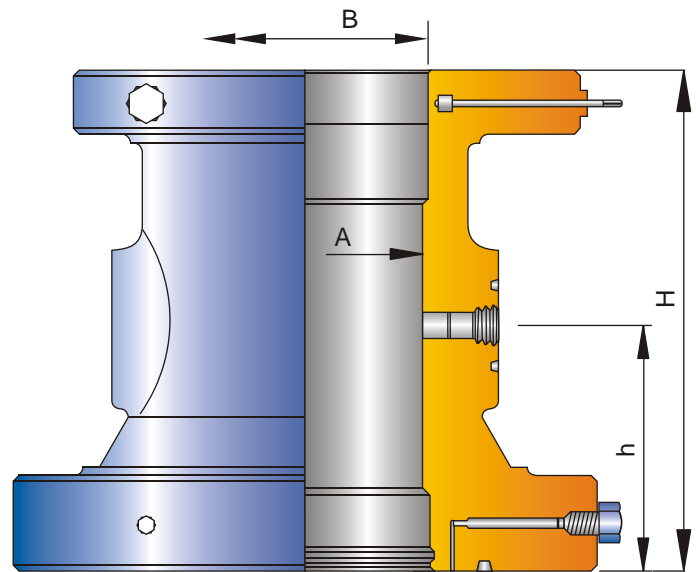

Parveen's Tubing Head Spool (PTHS)

Parveen's Tubing Head Spool (PTHS) Dimension.						
Flange Sizes		Overall Height(H)	Height Of Side Outlets (h)		Minimum Bore (A)	Top Flange Bore (B)
Bottom	Top					
9 X 2000	7 1/16 X 2000	16	7 15/16	6 1/2	7 1/32	
9 X 2000	7 1/16 X 3000	16	7 15/16	6 1/2	7 1/32	
9 X 2000	7 1/16 X 3000	16	7 15/16	6 13/16		7 1/32
9 X 3000	7 1/16 X 5000	16	8 1/16	6 13/16		7 1/32
11 X 2000	7 1/16 X 2000	16	8 1/16	6 13/16		7 1/32
11 X 2000	7 1/16 X 3000	16	8 1/16	6 13/16		7 1/32
11 X 3000	7 1/16 X 3000	19 1/2	10 1/2	6 13/16		7 1/32
11 X 3000	7 1/16 X 5000	22 7/8	12 3/8	6 13/16		7 1/32
11 X 5000	7 1/16 X 5000	23 1/2	10 3/4	6 13/16		7 1/32
11 X 2000	9 X 2000	16	8 1/16	8 1/16	8 3/4	
11 X 2000	9 X 3000	16	8 1/16	8 1/16	8 3/4	
11 X 3000	9 X 3000	19 1/2	10 1/2	8 1/16	8 3/4	
11 X 3000	9 X 5000	22 7/8	12 3/8	8 1/16	8 3/4	
11 X 5000	9 X 5000	25	12 3/4	8 1/16	8 3/4	
11 X 5000	7 1/16 X 10000	25	12 3/4	6 9/16	7 1/32	
11 X 5000	9 X 10000	25	12 3/4	8 1/16	8 3/4	
11 X 10000	7 1/16 X 10000	26 3/8	12 3/4	6 3/8	7 1/32	
11 X 10000	7 1/16 X 15000	27 3/8	12 3/4	6 3/8	7 1/32	

NOTE:

All Dimensions are in Inches.



TUBING HEAD SPOOL

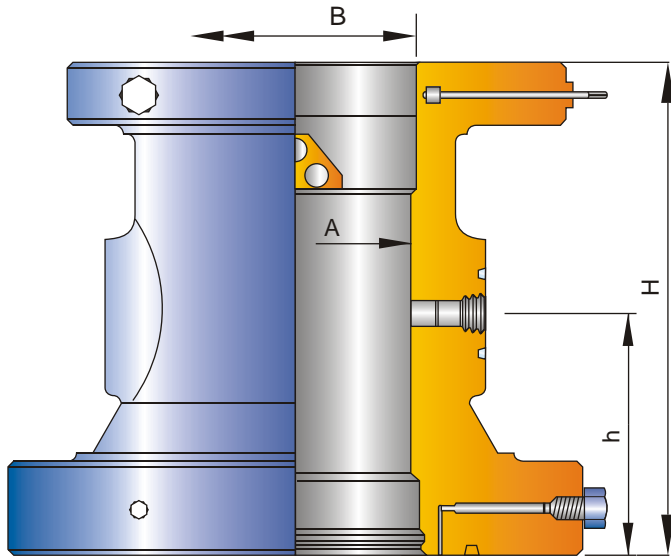

Parveen's Tubing Head Spool (PTHD)

PTHD Tubing Head Spools are designed for the popular split hanger suspensions for dual completions. It has welded wedges for hanger alignment and an open - face top flange.

Type 'PTHD' Tubing Spool accepts either the 'PTHDE', 'PTHSC', 'PTHDC' tubing hangers. This tubing spool is provided with a wedge to position the hanger. The standard outlets are 2 1/16 2000-10000 PSI WP studded. The outlets are threaded for the valve removal plug to allow for the removal of the valve. The bottom of the flange is designed for installing the type PBP-1 Bottom pack off (PP Seal for high pressure over 5000 PSI WP) and is provided with a plastic packing injection port and a test port. The top of the spool is provided with hold down screws to secure the tubing hanger.

Parveen's Tubing Head Spool (PTHD) Dimensions :-						
Flange Sizes		Overall Height(H)	Height Of Side Outlets (h)		Minimum Bore (A)	Top Flange Bore (B)
Bottom	Top					
11 X 2000	7 1/16 X 2000	20 1/2	10	6 3/8	6 61/64	
11 X 3000	7 1/16 X 3000	20 1/2	10	6 3/8	6 61/64	
11 X 3000	7 1/16 X 5000	22	11 1/2	6 3/8		6 61/64
11 X 5000	7 1/16 X 5000	23 3/4	11 11/16	6 3/8		6 61/64
11 X 5000	7 1/16 X 10000	25	12 3/4	6 3/8		6 61/64
11 X 3000	9 X 3000	22 1/4	11 5/8	6 13/16		8 59/64
11 X 3000	9 X 5000	23 3/8	12 3/4	6 13/16		8 59/64
11 X 5000	9 X 5000	25	12 3/4	6 13/16		8 59/64
11 X 5000	9 X 10000	27 3/8	14 3/8	6 13/16		8 59/64
13 5/8 X 3000	9 X 3000	22 3/4	11 5/8	8 1/16	8 59/64	
13 5/8 X 3000	9 X 5000	23 7/8	12 3/4	8 1/16	8 59/64	
13 5/8 X 5000	9 X 5000	24 7/8	12 3/4	8 1/16	8 59/64	
13 5/8 X 3000	7 1/16 X 3000	22 1/2	10	6 3/8	6 61/64	
13 5/8 X 3000	7 1/16 X 5000	23 5/8	11 1/8	6 3/8	6 61/64	
11 X 10000	7 1/16 X 10000	28 1/2	12 3/4	6 3/8	6 61/64	
11 X 10000	7 1/16 X 15000	29 1/8	13 3/8	6 3/8	6 61/64	
11 X 10000	9 X 10000	30 3/4	15	6 13/16	8 59/64	

NOTE:

All Dimensions are in Inches.

TOOLS & SERVICE EQUIPMENT

Casing Head Body Retrievable Wear Bushing (PRWB)

These retrievable wear bushings (PRWB) protect the inner containers of casing head bodies or spools during drilling operations.

When wear bushings are used, either hold down screws in the top flange of the casing head body or hold down flanges with hold down screws are required.

Retrieving Tool (PRT)

This tool (PRT) is meant for retrieving the wear bushing described above. It is inserted in the slot provided in the wear bushing top surface, rotated and then pulled up with the tools.

BOP Test Plug (PTP)

These plug Testers fit all nominal sizes of casing head bodies and tubing heads and are available with any standard tool joint.

The test plugs are assembled in the drill string and lowered to its seat in the casing head body or tubing head. Pipe rams of the preventors are then closed and hydraulic test pressure is applied below the rams.

Blind rams can be tested in the same manner after removing the drill string.

Back Pressure Valve (PBPV).

Tubing hanger bushing are furnished with female lift and suspension threads and are machined to accommodate the type (PBPV) back pressure valve as shown in the figure.

With Blowout Preventor equipment attached to the tubing head body, the tubing is run to the desired depth and the bushing, with the type (PBPV) back pressure valve installed, is made-up on the landing joint.

The wrap around hanger is then latched around the tubing below the hanger bushing and lowered thru the BOP to its position in the tubing head body by means of a landing joint.

After making sure that the hanger have fully landed in the head, hold down screws are fully tightened to compress the packing and secure it in place. Thereafter the landing joint & BOP may be removed.

Attach the landing joint and raise the tubing enough to install a spider and slips. With tubing weight on the slips, remove landing joint.



**Casing Head Body Retrievable
Wear Bushing (PRWB)**

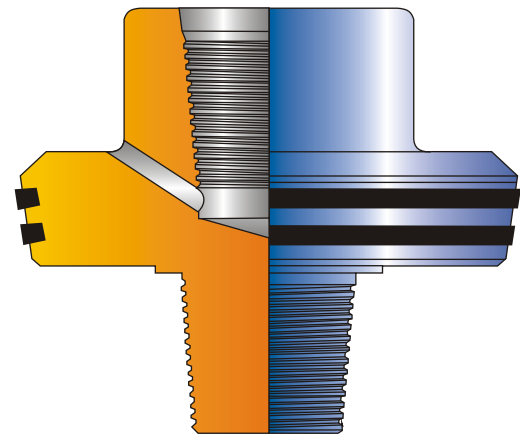

**Casing Head Plug
Type Tester (PTP)**

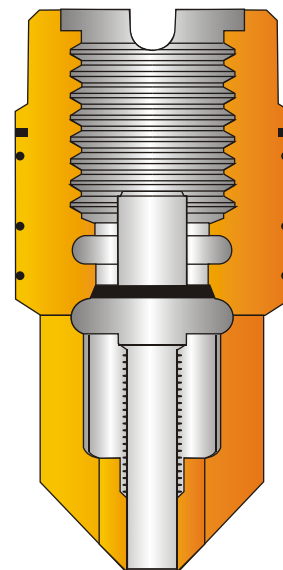

**Type (PBPV) Back
Pressure Valve**

TOOLS & SERVICE EQUIPMENT

The Hanger Spool with X-Mas Tree Manifold attached is then lowered and sealed on the hanger bushing. The union nut may now be made up by hand and a spanner wrench. The tree cannot now be rotated.

Raise the tree assembly enough to remove the spider and slips. At this point, the well can be displaced and the packer set under complete pressure control.

Final nipple up operations are then completed and the type PBPV back pressure valve is removed from the hanger bushing with a lubricator.

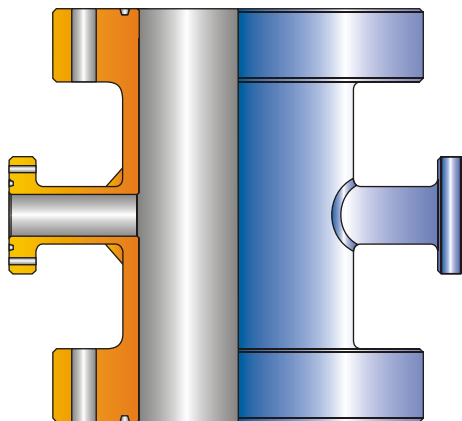

Flanged Drilling Spool (PFDS)

Flanged Drilling Spool (PFDS)

These are designed to allow unrestricted circulation of mud in the well and provide flexibility in arranging flow line openings in blowout preventor hookups. Studded or open faced ends and outlet connections can be provided. Generally hub of the flanged outlet is welded. Height of spool will vary from 24" -36". However spools as per specific need of customers can also be provided.

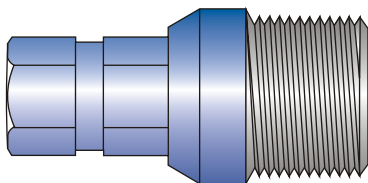

Type (PVRP) Plug

Valve Removal Plugs (PVRP)

All flanged or studded outlets on PARVEEN's casing heads, casing spools and tubing heads are threaded for valve removal plugs. All plugs have standard API Line Pipe Threads and are small enough to pass thru the valve to be removed. The plug is installed when the valve is to be removed and removed when the valve is to be installed.

Valve Removal Tool (PVRT)

These are generally pressure-balanced manual hydraulic tool designed for safe and reliable operations in the installation and removal of valve removal plugs, in order to install or replace a well-head outlet valve under pressure conditions.

This tool is also designed to accommodate 2 1/16", 2 9/16", 3 1/8" Valve upto 10000 PSI WP. Adapter may be provided for use with 1 13/16", 2 1/16", 2 9/16", 3 1/8" flanged valves and screwed end valves. Various sizes of valve removal plug sockets are also provided for the respective sizes of plugs.

In the figure above, Needle Valve 'A' is located next to pressure gauge on manifold by-pass assembly and needle valve 'B' is connected to 1/2" NPT TEE on far end of manifold bypass assembly. Needle Valve 'C' is a bleeder valve located behind flange packing.

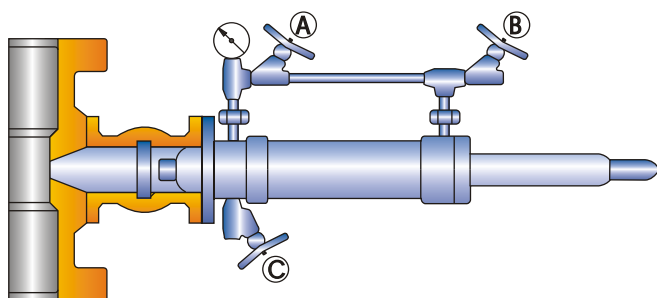

Valve Removal Tool (PVRT)



TOOLS & SERVICE EQUIPMENT

Lubricator (PL)

PARVEEN's Lubricators which connect directly to the top of a X-Mas tree above the master valve are available in various sizes and end connections and pressure ratings varying from 5000 to 20000 PSI both for standard and sour service.

Operating a Lubricator is by far the most dangerous aspect of well head service work. Therefore extreme caution has to be exercised while operating this tool.

Measurement of Rod travel is done as follows:

- a. Measure from the tie down piece on the tubing head to the tree cap for a ball weevil hanger.
Or
- b. Measure from the top of the tubing head adaptor bottom flange to the tree cap on a hanger bushing completion.

In each case the window section of lubricator must also be measured. This will ensure that the proper length of the rod will be used. Most lubricator rods are marked in 5 such increments:

a. Needle Valve A

Valve located in manifold by pass assembly closest to adaptor flange.

b. Needle Valve B

Valve located on manifold bypass assembly closest to the first UNION connection.

(NOTE: In lubricators upto 5000 PSI, needle valve B is also used as a bleed down valve. Needle valve C is used in 10000, 15000 & 20000 PSI lubricators to equalize pressure throughout the tool and not as bleed down valves.)

c. Needle Valve C

Only valve with a pressure gauge attached. Available in 10000, 15000 & 20000 PSI lubricators.

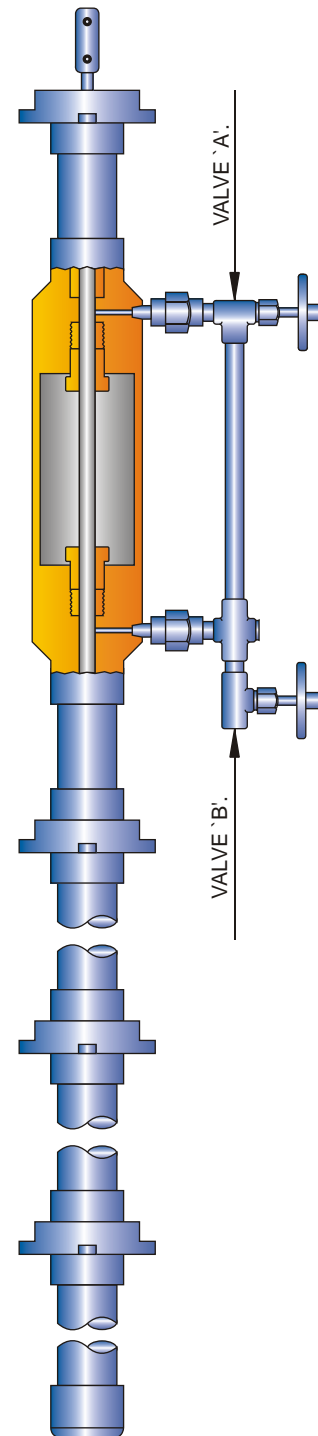

Lubricator (PL)



CHOKE VALVE

H2 TYPE CHOKE VALVE

PARVEEN manufacture both Positive and Adjustable chokes in pressure rating up to 15,000 psi WP. With different style of end connection.

Adjustable Chokes are meant for variable flow. It has externally controlled indicator showing orifice size in the increment of 1/64th inch. The variation in choke size is achieved by rotating hand wheel to obtain desired flow rate at down stream side

PARVEEN Adjustable Chokes Contain following features:

- Interchangeability of parts to construct a positive, adjustable, or combination choke.
- Bonnet nut has rugged integrally forged lugs for hammering nut loose.
- Built-in safety feature which releases residual pressure in the choke body before the nut is fully removed. The inside of the choke body is vented to atmosphere after the bonnet nut is partially removed.
- Interchangeability of component parts for a particular pressure range. For example, the same blanking plugs and bonnet assemblies are used in nominal 2" 2000 through 10,000 psi WP.
- Stainless steel adjustable choke needle and seat (Tungsten Carbide/ Ceramic lining needle and seat also available for severe service applications)

Different end connections (API / ANSI, flanged / Threaded) are available upon request.

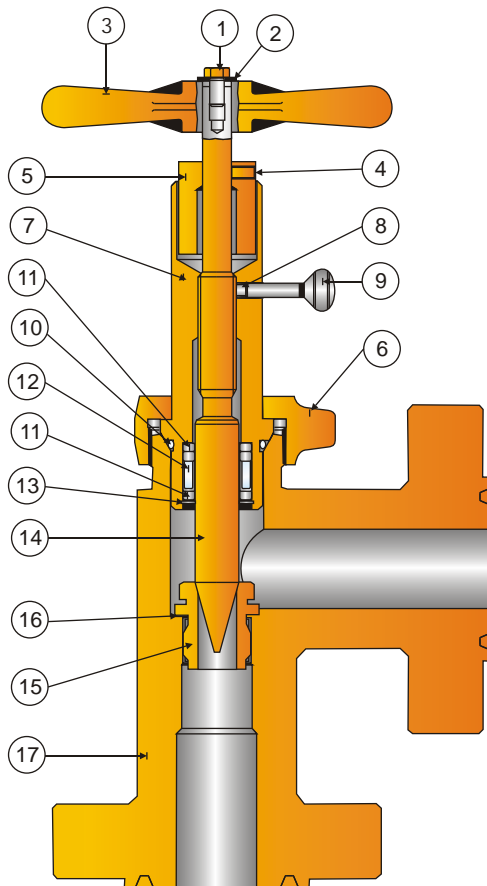

Adjustable Choke

Part List		
ITEM	DESCRIPTION	QTY.
1	HEX BOLT	1
2	WASHER	1
3	HANDLE	1
4	HEX. SOC. SET SOCIETY	1
5	INDICATOR	1
6	BONNET NUT	1
7	BONNET	1
8	NYLON PLUG	1
9	THUMB SCREW	1
10	'O' RING-BONNET	1
11	JUNK RING	2
12	'J' PACKING + BACK-UP RING	1
13	INT. RETAINER RING	1
14	NEEDLE	1
15	SEAT	1
16	GASKET	1
17	BODY	1

Size & WP	Max Orifice Dia
2 1/16 x 2000	25.4 MM
2 9/16 x 2000	50.8 MM
3 1/8 x 2000	50.8 MM
4 1/16 x 2000	76.2 MM
2 1/16 x 3000	25.4 MM
2 9/16 x 3000	50.8 MM
3 1/8 x 3000	50.8 MM
4 1/16 x 3000	76.2 MM
2 1/16 x 5000	25.4 MM
2 9/16 x 5000	50.8 MM
3 1/8 x 5000	50.8 MM
4 1/16 x 5000	76.2 MM
2 1/16 x 10000	25.4 MM
2 9/16 x 10000	50.8 MM
3 1/16 x 10000	50.8 MM
2 1/16 x 15000	25.4 MM
3 1/16 x 15000	50.8 MM



CHOKE VALVE

Positive Chokes & Beans

Positive Chokes accommodate fixed orifice dimensions. All PARVEEN Adjustable Chokes can be converted into Positive Chokes by replacing the bonnet assembly with an appropriate blanking plug assembly and choke bean .

CHOKE BEANS :

- PARVEEN choke beans are suitably hardened to maintain accuracy level for longer period.
- Tungsten Carbide lined choke Beans are available for high pressure drop and severe application

BEAN WRENCH:

PARVEEN Bean Wrench come with hexagonal socket box for Bean Adapter and Bean separately. The Adjustable choke seat and Bean Adapter are accommodated in same wrench for a particular size .

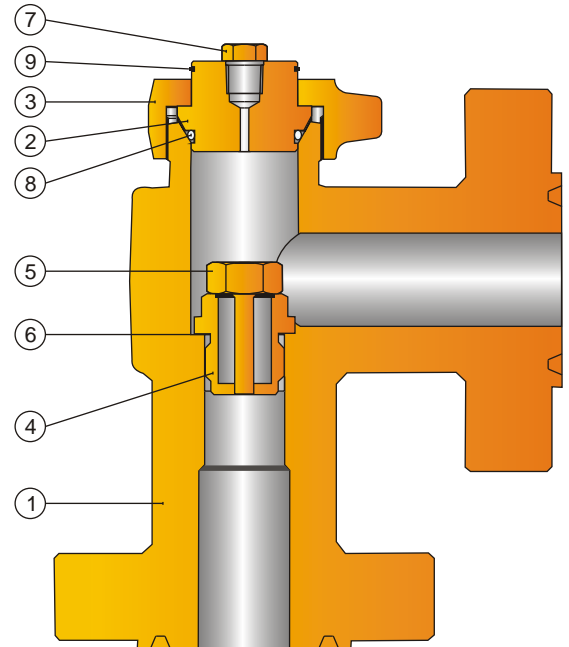

Positive Choke

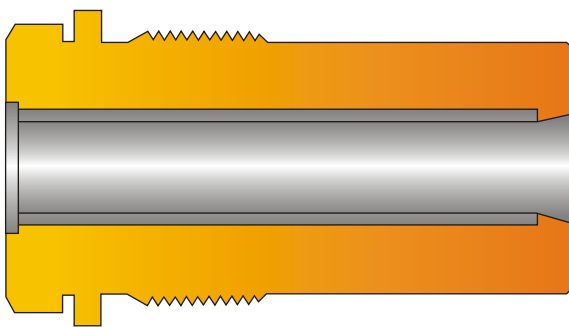

Choke Bean (BJ Type)

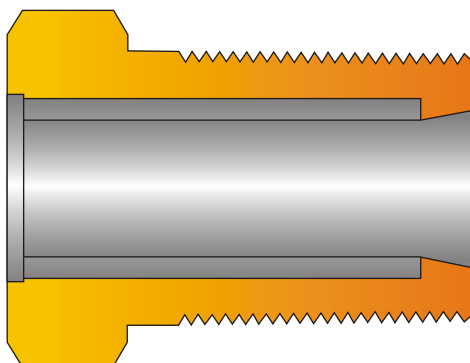

Choke Bean (HJ Type)

Part List		
ITEM	DESCRIPTION	QTY.
1	BODY	1
2	BONNET	1
3	BONNET NUT	1
4	BEAN ADAPTER	1
5	CHOKE BEAN	1
6	GASKET	1
7	PLUG (½" NPT)	1
8	'O' RING-BONNET	1
9	EXT. RETAINER RING	1

CHOKE VALVE

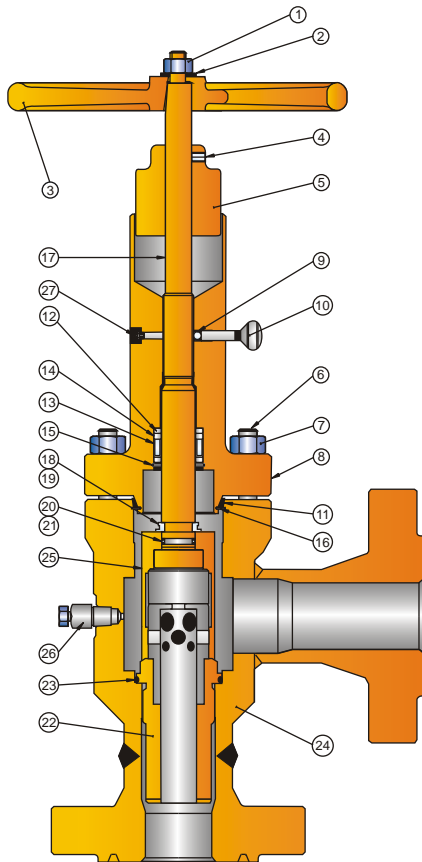

External Sleeve Control Choke

PARVEEN External sleeve control choke, (Model-ES)

PARVEEN External sleeve control chokes minimize erosion and improve flow characteristics suitably for erosive service and under high pressure drop, with sand concentration. It applies the principle of "flow Impingement" to dissipate and contain the destructive forces of cavitation, within the heavy duty thick walled cage of tungsten carbide.

Other features :

- Spring loaded pressure energized stem seal.
- Field proven metal bonnet seal .
- Dependable positive shut-off .

Size & WP	Max Orifice Dia
2.1/16 x 2000	25.4 mm
2.9/16 x 2000	50.8 mm
3.1/8 x 2000	50.8 mm
4.1/16 x 2000	76.2 mm
2.1/16 x 3000	25.4 mm
2.9/16 x 3000	50.8 mm
3.1/8 x 3000	50.8 mm
4.1/16 x 3000	76.2 mm
2.1/16 x 5000	25.4 mm
2.9/16 x 5000	50.8 mm
3.1/8 x 5000	50.8 mm
4.1/16 x 5000	76.2 mm
2.1/16 x 10000	25.4 mm
2.9/16 x 10000	50.8 mm
3.1/16 x 10000	50.8 mm
2.1/16 x 15000	25.4 mm
3.1/16 x 15000	50.8 mm

Part List		
ITEM	DESCRIPTION	QTY.
1	HEX NUT	1
2	WASHER	1
3	HANDWHEEL	1
4	HEX, SOC. SET SCREW	1
5	INDICATOR	1
6	STUD	8
7	NUT	8
8	BONNET	1
9	NYLON BALL	1
10	THUMB SCREW	1
11	RING-BONNET	1
12	JUNK RING	2
13	SEAL	1
14	BACK - UP RING - SEAL	1
15	INT. RETAINER RING	1
16	RETAINER RING - COIL TYPE	1
17	STEM	1
18	RING (2 HALVES) - STEM	1
19	INT. RETAINER RING	1
20	'O' RING	1
21	BACK-UP RING (SCARF CUT)	1
22	SEAT	1
23	SEAT SEAL	1
24	BODY	1
25	FLOW RING	1
26	BODY VENT FITTING	1
27	GREASE NIPPLE1	
28	RIVET TAG (NOT SHOWN)	4
29	NAME PLATE (NOT SHOWN)	1
30	FLANGE PROTECTOR (NOT SHOWN)	2



GATE VALVE

MANUAL GATE VALVE

PARVEEN manufacture Gate valves required for drilling and production operation in Slab and Expanding Gate style.

PARVEEN EXPANDING GATE VALVE MODEL 'M':

EXPANDING STYLE GATE VALVES FOR 2000-5000 PSI. WP. APPLICATION

- Full bore through conduit
- Block and Bleed Mechanism
- Long-life seat
- Positive Seal by expand Mechanism
- In-line maintenance
- Non- Rising and Non- Balanced Stem
- Thrust bearing for the low torque operation

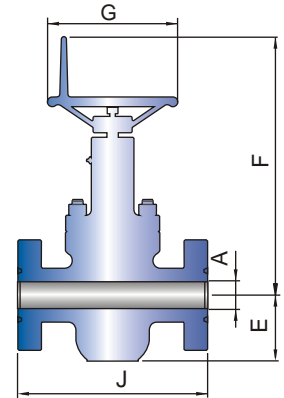

**Flanged Gate Valves
(MODEL - M)**

FLANGED GATE VALVES OVERALL DIMENSIONS (As per API-6A Standard)								
Size	Working Pressure (PSI)	A	E	F	G	J	N	Wt (lbsf)
2 1/16	2000	2 1/16	4 13/16	19 1/4	11	11 5/8	13	91
	3000/5000		5 1/16	19 7/16	13	14 5/8		150
2 9/16	2000	2 9/16	5 5/8	20 3/16	13	13 1/8	15 1/2	125
	3000/5000		5 15/16	20 7/16	16	16 5/8		205
3 1/8	2000	3 1/8	6 15/16	22 1/2	13	14 1/8	20	181
	3000		7 5/16	22 3/4	16	17 1/8		265
	5000		7 5/16	22 3/4	16	18 5/8		296
4 1/16	2000	4 1/16	8 5/8	25 15/16	16	17 1/8	24 1/2	345
	3000		9 1/16	26 3/8	20	20 1/8		515
	5000		9 1/16	26 3/8	20	21 5/8		530

PARVEEN FLANGED GATE VALVE MODEL 'M':

The PARVEEN Flanged end gate valves are of the same standards as threaded end valves. Flanged end will conform to API-6A Spec. For Trims refer Trim Chart.

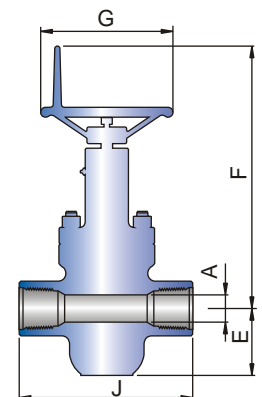

**Threaded Gate Valves
(MODEL - M)**

THREADED GATE VALVES OVERALL DIMENSIONS								
Size	Working Pressure (PSI)	A	E	F	G	J	N	Wt (lbsf)
2 1/16	2000	2 1/16	4 13/16	19 1/4	11	9 5/8	13	71
	3000/5000		5 1/16	19 7/16	13			99
2 9/16	2000	2 9/16	5 5/8	20 3/16	13	10 1/4	15 1/2	92
	3000/5000		5 15/16	20 7/16	16			125
3 1/8	2000	3 1/8	6 15/16	22 1/2	13	11 3/8	20	152
	3000/5000		7 5/16	22 3/4	16			195
4 1/16	2000	4 1/16	8 5/8	25 15/16	16	13	24 1/2	265
	3000/5000		9 1/16	26 3/8	20			379

NOTE:

Standard Temperature Rating: -20° F to +250° F N = Numbers of Turns open.
All Dimensions are in Inches.



GATE VALVE

Parveen High Temperature Service : (Model T)

Parveen High Temperature gate valve uses parallel expanding gate to obtain perfect shutoff. The sealing is metal - to metal, both on the up and down stream of the valve, and unaffected by vibration and heat. The valve is the standard Model 'E' gate valve, modified with extended bonnet and stem to place the stem packing outside the critical heat zone. Other features and trim chart shall remain same for model E gate valves.

Pressure Derating Table : (As recommended by API 6A)								
-20 to 250 F	300 F	650 F	400 F	450 F	500 F	550 F	600 F	650 F
2000	1955	1905	1860	1810	1735	1635	1540	1430
3000	2930	2860	2785	2715	2605	2455	2310	2145
5000	4880	4765	4645	4525	4340	4090	3850	3575

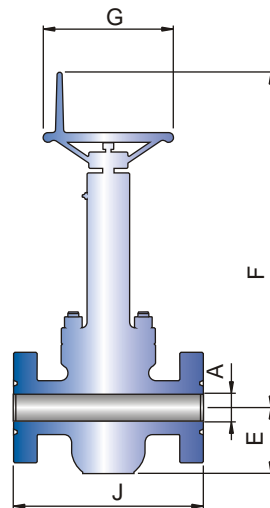

DIMENSIONAL DATA FOR HIGH TEMPERATURE VALVE, UPTO 650 F								
Size	Working Pressure	A	E	F	G	J	N	WT IN LBS
2.1/16"	2000	2.1/16	4.13/16	25.1/4"	11	11.5/8	13	96
	3000/5000			25.7/16				165
2.9/16	2000	2.9/16	5.5/8	26.3/16	13	13.1/8	15.1/2	130
	3000/5000			26.7/16				220
3.1/8	2000	3.1/8	6.15/16	28.1/2	13	14.1/8	20	186
	3000			28.3/4				273
	5000			28.3/4				311
4.1/16	2000	4.1/8	8.5/8	31.15/16	16	17.1/8	24.1/2	351
	3000			32.3/8				523
	5000			32.3/8				545

Flange specification conforms to API Standard 6A



GATE VALVE

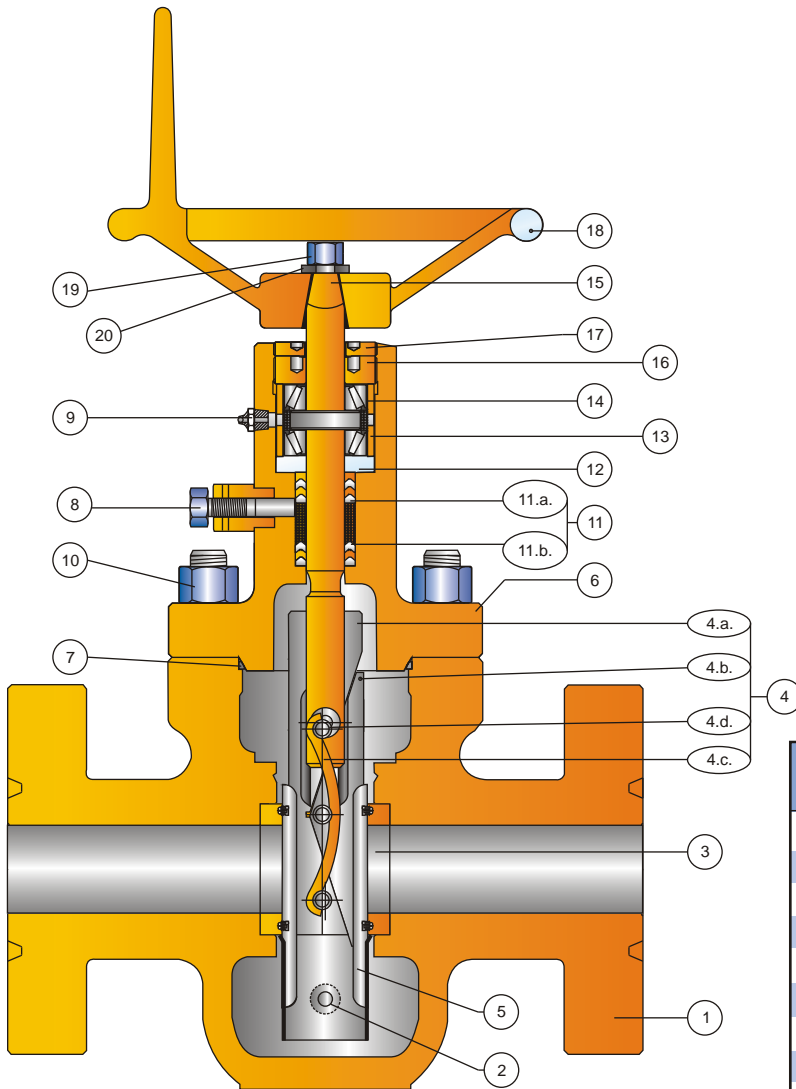

Flanged Gate Valve (Model - M)

Part List		
ITEM	DESCRIPTION	Qty.
1	BODY	1
2	BODY GREASE FITTING	2
3	SEAT ASSY.	2
3a	SEAT	2
3b	TEFLON/T.F.E. RING	2
4	GATE SEGMENT ASSY.	1
4a	GATE	1
4b	SEGMENT	1
4c	SPRING	2
4d	GATE PIN	6
5	GATE GUIDE	2
6	BONNET	1
7	BONNET SEAL RING	1
8	PACKING FITTING	1
9	BONNET GREASE FITTING	1
10	STUD WITH NUT	8
11	PACKING SET	6
11a	HEADER PACKING RING	2
11b	'V' PACKING RING	4
12	PACKING RETAINER BUSHING	1
13	BEARING SPACER SLEEVE	1
14	THRUST BEARING	2
15	STEM	1
16	BEARING RETAINER NUT	1
17	BEARING RETAINER LOCK NUT	1
18	HAND WHEEL	1
19	HAND WHEEL NUT	1
20	WASHER FOR HANDWHEEL NUT	1



GATE VALVE

SLAB STYLE GATE VALVES FOR 2000-10,000 PSI W.P. APPLICATION

Main features:

- Full bore through conduit
- Block and Bleed Mechanism
- Floating seat with self relief function
- In-line maintenance
- Metal to Metal sealing
- Metal to Metal stem back seat
- Heavy duty bearing for Low torque and easy operation
- Non-Rising and Non-Balanced Stem
- Forged Body and Bonnet Construction

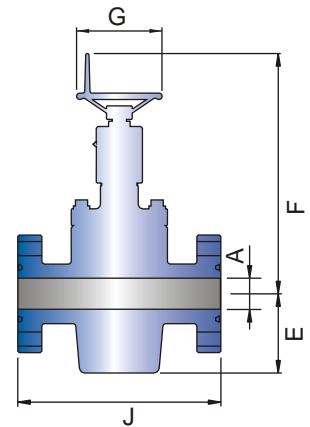

Slab Flanged Gate Valve (Model - S)

FLANGED GATE VALVE OVERALL DIMENSIONS. (As per API. 6A Standard)								
Size	Working Pressure (PSI)	A	E	F	G	J	N	Wt (lbsf)
2 1/16	2000	2 1/16	5 5/8	21 1/8	14	11 5/8	12 1/2	110
	3000/5000					14 5/8		182
2 9/16	2000	2 9/16	6 1/2	21 7/8	14	13 1/8	15 1/4	137
	3000/5000					16 5/8		255
3 1/8	2000	3 1/8	7 3/8	22 13/16	14	14 1/8	18 1/4	193
	3000				14	17 1/8		282
	5000				18 1/2	18 5/8		360
4 1/16	2000	4 1/16	9 1/8	24 7/16	16	17 1/8	23 1/2	395
	3000				18 1/2	20 1/8		450
	5000				21 5/8	21 5/8		545
1 13/16	10,000	1 13/16	5 3/4	21 1/8	14	18 1/4	12 1/2	270
2 1/16	10,000	2 1/16	5 7/8	21 1/8	18 1/2	20 1/2	12 1/2	275
2 9/16	10,000	2 9/16	6 13/16	21 7/8	18 1/2	22 1/4	15 1/4	485
3 1/16	10,000	3 1/16	8 1/16	21 13/16	24	24 3/8	18 1/4	680
4 1/16	10,000	4 1/16	10 1/16	24 11/16	24	26 3/8	23 1/2	1050

NOTE:

Standard Temperature Rating: - 20° F to + 250° F. N = Numbers of Turn open.

THREADED GATE VALVE OVERALL DIMENSIONS.								
Size	Working Pressure (PSI)	A	E	F	G	J	N	Wt (lbsf)
2 1/16	3000/5000	2 1/16	5 5/8	21 1/8	14	9 5/8	12 1/2	130
2 9/16	3000/5000	2 9/16	6 1/2	21 7/8	14	10 1/4	15 1/4	190
3 1/8	3000	3 1/8	7 3/8	22 13/16	14	11 3/8	18 1/4	210

NOTE:

Standard Temperature Rating: - 20° F to + 250° F. N = Numbers of Turn open.

All Dimensions are in Inches.

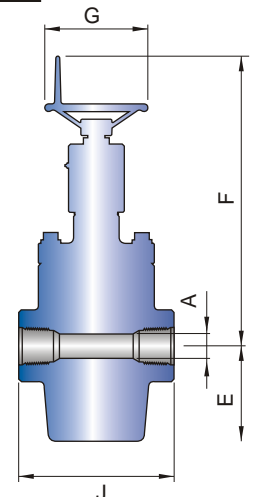

Slab Threaded Gate Valve (Model - S)



GATE VALVE

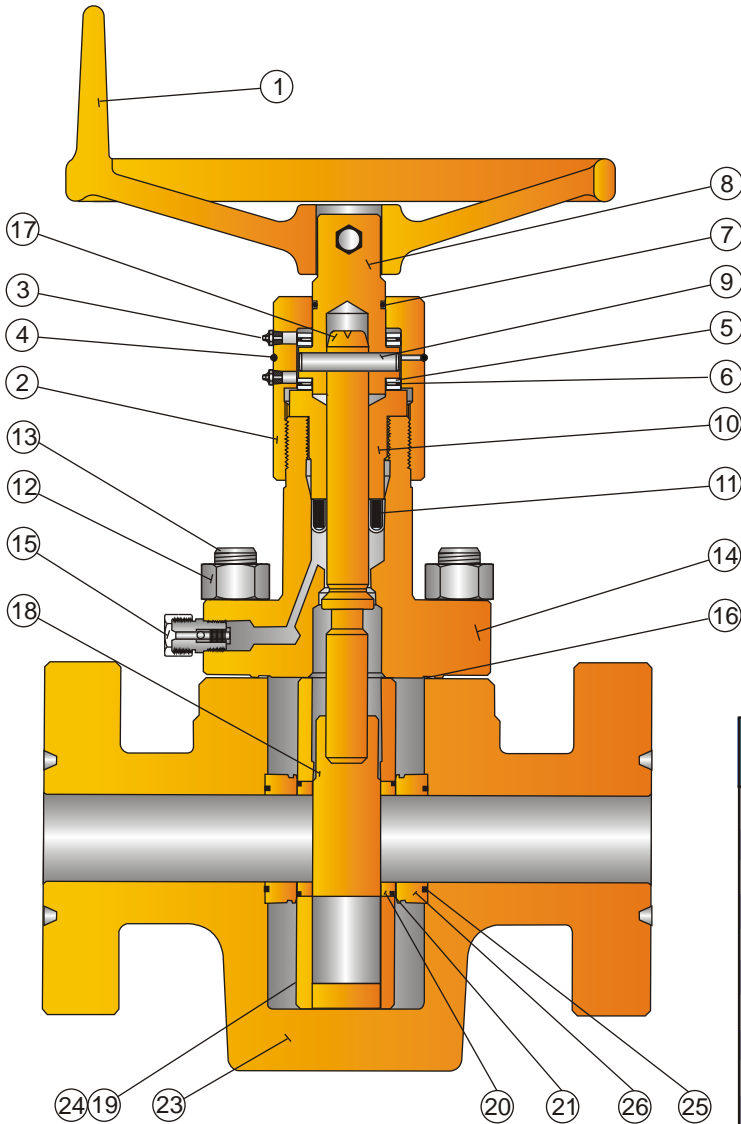

Slab Gate Valve (Model - S)

Part List		
ITEM	DESCRIPTION	Qty.
1	HANDWHEEL ASSEMBLY	1
2	BEARING CAP	1
3	GREASE FITTING	2
4	O-RING	1
5	BEARING RACE	4
6	THRUST BEARING	2
7	O-RING	1
8	STEM ADAPTER	1
9	STEM PIN	1
10	PACKING GLAND	1
11	'J' PACKING	1
12	NUT	8
13	STUD	8
14	BONNET	1
15	GREASE FITTING	1
16	GASKET	1
17	STEM	1
18	GATE	1
19	RETAINER PLATE	2
20	SEAT RING	2
21	SEAL RING (SEAT RING)	2
22	PIN (Not shown)	2
23	BODY	1
24	GUIDE	2
25	SEAL RING (BODY BUSHING)	2
26	BODY BUSHING	2
27	NAME PLATE (Not shown)	1



TYPICAL SINGLE & DUAL COMPLETION WELLHEAD & X-MAS TREE ASSEMBLIES

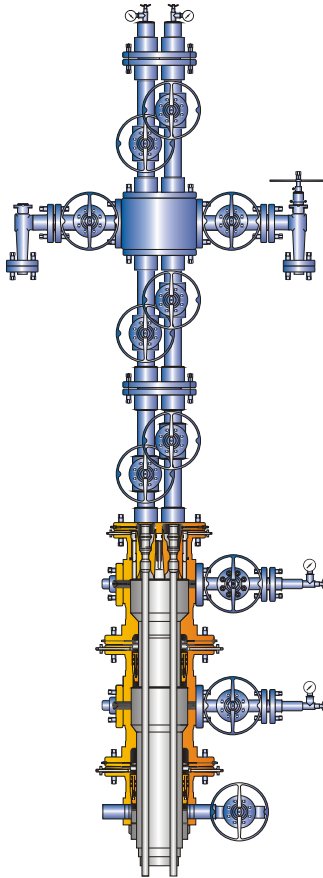

Dual Completion

THREADED CONNECTIONS:

All Integral equipment internal and outlet connection including Casing and Tubing Hanger which have API Threads, conform to API-5B stipulations for concerned tolerances.

CHRISTMAS TREE:

The equipment manufactured by PARVEEN include Tubing Head Adaptors, Valves, Trees, Crosses, Top Connectors and Chokes which can be assembled together and assembly can be used to provide controlled access to the Tubing String bore and control the rate of production.

PARVEEN not only manufactures X-Mas Trees for single and multiple Tubing String installation but also the composite (block) X-Mas Trees for single and multiple Tubing String installations.

Testing of X-Mas Trees is done as per Latest standard of API-6A which covers drift test and Hydrostatic test.

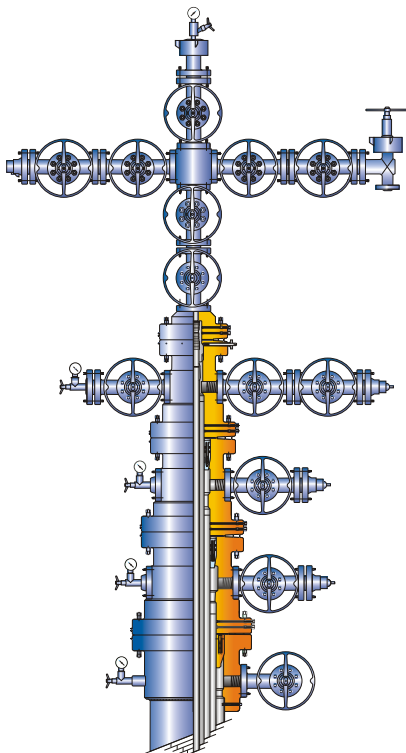

Single Completion

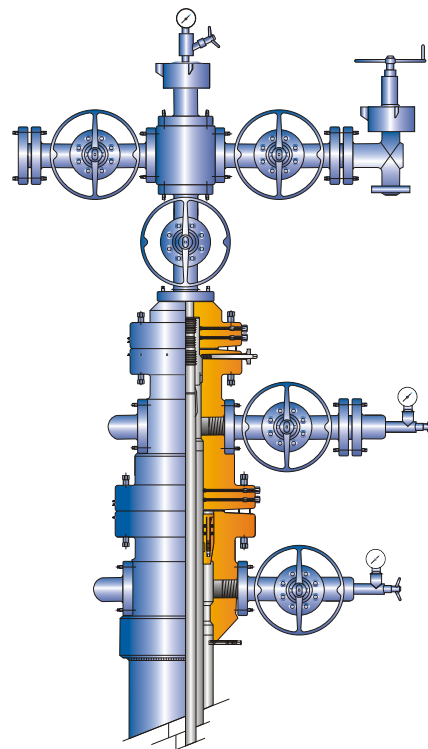

Single Completion

CHOKE AND KILL MANIFOLD

PARVEEN fabricates custom designed choke and kill manifold :

1) In oil / gas well drilling operation, drilling fluids (Muds) of designed gravity are used to overcome sub-surface pressure or the influx of formation fluid. On some occasion, kicks are experienced with change of pressure of formation while drilling. This is necessary to build up drilling fluid density to prevent influx of formation fluid. The Choke and Kill Manifold allows the driller to regulate back-pressure on the formation while gradually density of the drilling fluid is built up by circulation with closed B.O.P., till the well is stabilized and drilling is resumed.

The Choke and Kill Manifold are available up to 10,000 PSI in sizes of 2" to 3" for standard and sour services. Other type of Manifold (stand pipe, cementing etc.) can also be made available.

2) For well Testing / Completion / Intervention, Industry uses varies configuration of Manifold, as per requirement of Service / Operating Companies, PARVEEN designs and fabricates custom made manifold in sizes of 2" to 3" up to 10,000 PSI for standard and sour services for following application.

- (a) Choke Manifold For flow back/work over
- (b) Production Manifold for diverting flow through test separator or vent or burner.
- (c) Gas Manifold for Diverting gas through orifice meter or burner.
- (d) Data Recorder for recording flowing pressure and temperature.
- (e) Stimulation / Treatment for Well stimulation/treatment service.

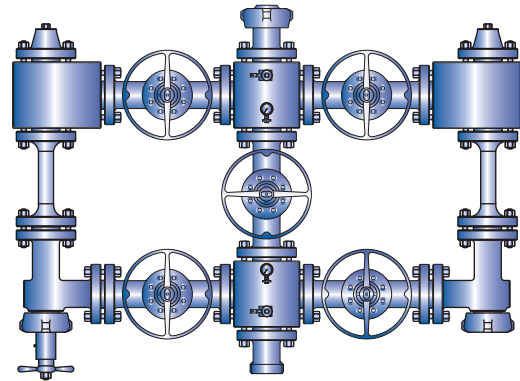

Choke Manifold

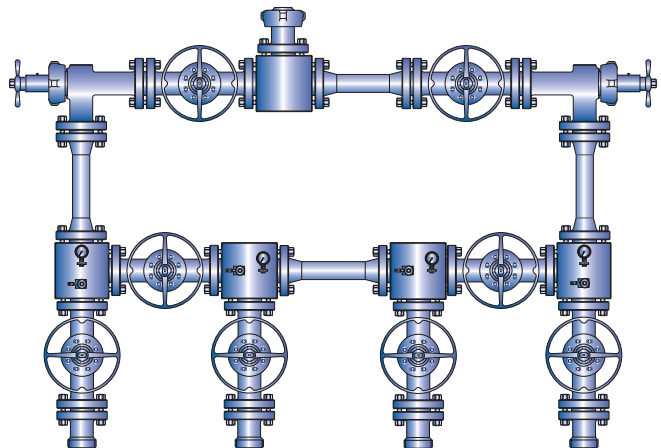

Eruption Manifold

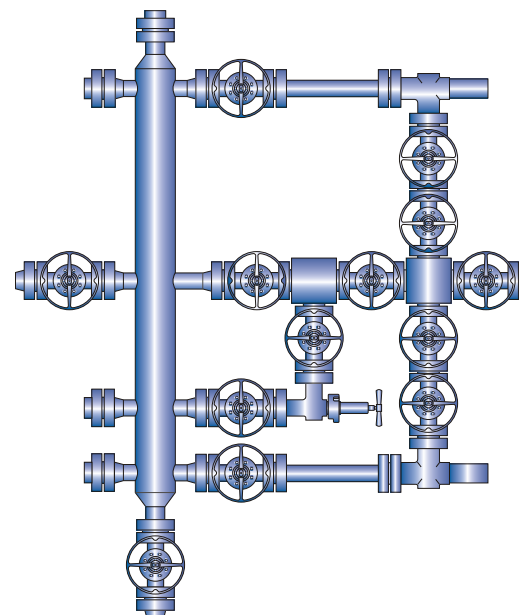

Choke & Kill Manifold



X-MAS TREE CAP

PARVEEN X-Mas Tree cap is a top connector which is used on the top of X-Mas Tree, It's main function is to provide access to the X-Mas Tree bore. It is basically consisting of a Flanged body, Blanking Plug, Hammer Nut as principal parts and Circlip & O-ring as secondary parts. Blanking Plug has a provision to accommodate pressure gauge to ascertain inside pressure of the well. Inside of Flanged body is having API-UP TBG thread as lift thread.

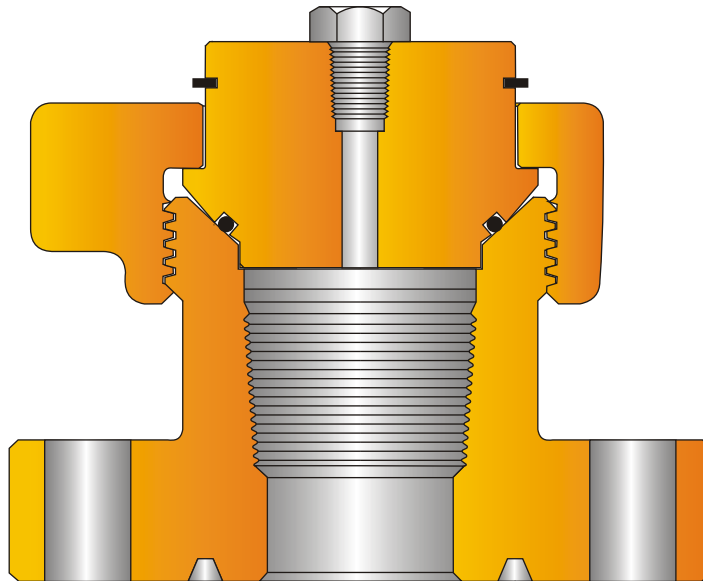

Single Christmas Tree Cap

SPECIFICATIONS			
Nominal Size and WP.	Lift Thread	Bore	Height
2 1/16-2000	2 3/8 API UP TBG	2 21/64	7 1/8
2 9/16-2000	2 7/8 API UP TBG	2 53/64	7 1/16
3 1/8-2000	3 1/2 API UP TBG	3 1/8	9 9/16
3 1/8-3000	3 1/2 API UP TBG	3 1/8	9 13/16
2 1/16-5000	2 3/8 API UP TBG	2 21/64	7 3/4
2 9/16-5000	2 7/8 API UP TBG	2 53/64	8 1/16
3 1/8-5000	3 1/2 API UP TBG	3 1/8	10 1/16
4 1/16-5000	4 1/2 API UP TBG	4 13/64	12 1/8
2 1/16-10000	2 3/8 API UP TBG	2 1/16	8
2 9/16-10000	2 7/8 API UP TBG	2 9/16	7 9/16
3 1/16-10000	3 1/2 API UP TBG	3 1/16	10 5/16
4 1/16-10000	4 1/2 API UP TBG	4 1/16	13 1/8

NOTE:

All Dimensions are in inches.



SINGLE COMPLETION COMPONENT

PARVEEN also manufactures different types of Single Completion Components as per API-6A or Customer specification.

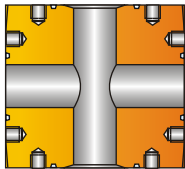

Studded Cross

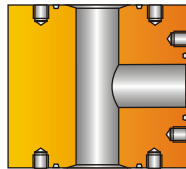

Studded Tee

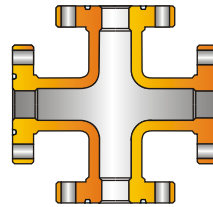

Flanged Cross

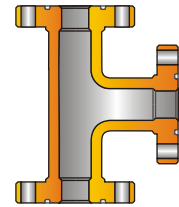

Flanged Tee

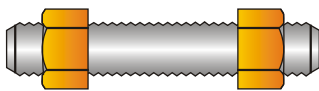

Stud With Nuts

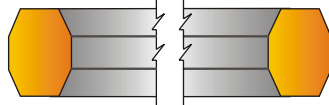

Octagonal Ring Gasket

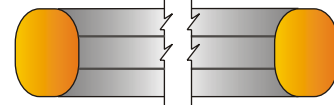

Oval Ring Gasket

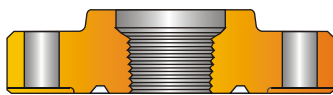

Threaded Flange

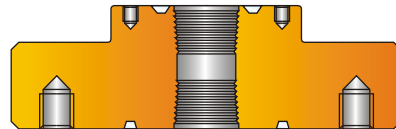

Double Studded Adaptor Flange



Blind Flange

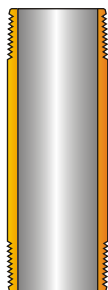

Threaded Nipple



Tapped Bull-Plug

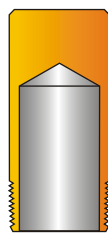

Solid Bull-Plug



Solid Bull-Plug

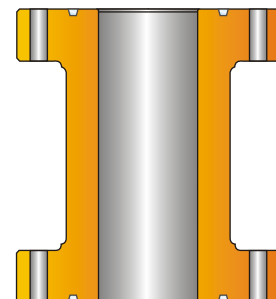

Spacer Spool

NOTE:

Multiple Completion Components (e.g. Dual Manifold Tee, Dual Adaptor Flange, Dual Completion Flanges, Multiple Completion Sub Seal etc.) can also be provided upon request.