

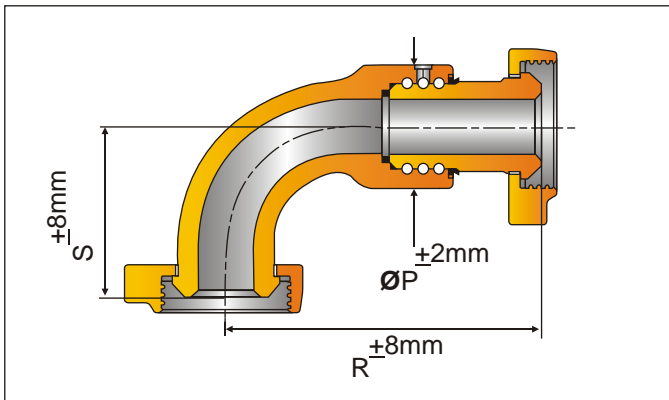

LONG SWEEP SWIVEL JOINT (BASIC DIMENSIONS) STYLE-30



STYLE - 30 LONG SWEEP SWIVEL JOINT
 END CONNECTION = UNION (M X M) FIG.602/1002/1502*
 MODEL:- PLSSJ - 30MM

SIZE	ØP (MM)	ØP (INCH)	R (MM)	R (INCH)	S (MM)	S (INCH)	WT. (LBSF)	WT. (KGF)
1"	65	2.41	214	8.42	115	4.52	18.3	8.3
1 1/2"	108	4.25	259	10.20	151	5.94	51.0	23.0
2"	108	4.25	277	10.90	156	6.14	52.0	23.5
3"	148	5.82	369	14.52	230	9.05	101.4	46.0
4"	185	7.28	452	17.80	310	12.20	227.0	103.0

* FOR 2002 /2202 UNION ENDS CONSULT FACTORY

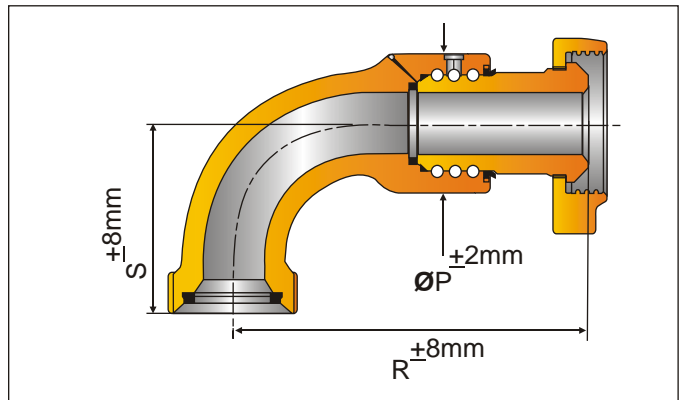

STYLE - 30 LONG SWEEP SWIVEL JOINT
 END CONNECTION = UNION (M X F) FIG.602/1002/1502*
 MODEL:- PLSSJ - 30MF

SIZE	ØP (MM)	ØP (INCH)	R (MM)	R (INCH)	S (MM)	S (INCH)	WT. (LBSF)	WT. (KGF)
1"	65	2.41	214	8.42	111	4.37	15.0	6.7
1 1/2"	108	4.25	259	10.20	128	5.04	41.4	18.8
2"	108	4.25	277	10.90	145	5.70	42.0	19.0
3"	148	5.82	369	14.52	203	8.00	86.0	39.0
4"	185	7.28	452	17.80	247	9.72	181.0	82.0

* FOR 2002 /2202 UNION ENDS CONSULT FACTORY

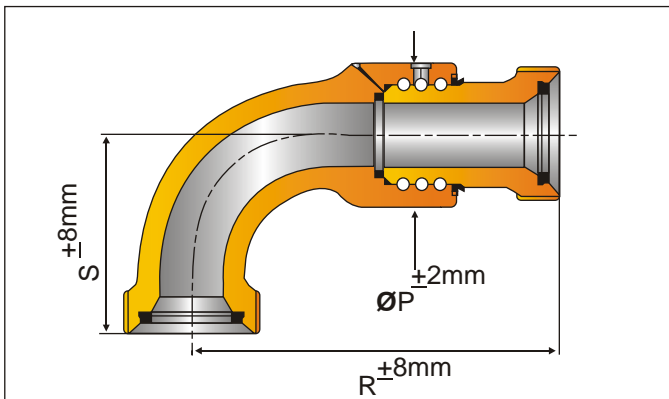

STYLE - 30 LONG SWEEP SWIVEL JOINT
 END CONNECTION = UNION (F X F) FIG.602/1002/1502*
 MODEL:- PLSSJ - 30FF

SIZE	ØP (MM)	ØP (INCH)	R (MM)	R (INCH)	S (MM)	S (INCH)	WT. (LBSF)	WT. (KGF)
1"	65	2.41	214	8.42	111	4.37	10.5	4.75
1 1/2"	108	4.25	259	10.20	128	5.04	30.2	13.7
2"	108	4.25	277	10.90	145	5.70	31.0	14.0
3"	148	5.82	369	14.52	203	8.00	73.0	33.0
4"	185	7.28	452	17.80	247	9.72	137.5	62.4

* FOR 2002 /2202 UNION ENDS CONSULT FACTORY

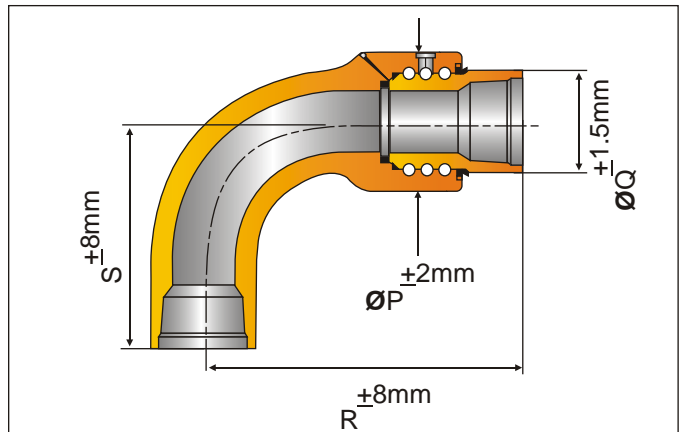

STYLE - 30 LONG SWEEP SWIVEL JOINT
 END CONNECTION = THREADED
 MODEL:- PLSSJ - 30T

SIZE	ØP (MM)	ØP (INCH)	ØQ (MM)	ØQ (INCH)	R (MM)	R (INCH)	S (MM)	S (INCH)	WT. (LBSF)	WT. (KGF)
1"	65	2.41	48.5	1.91	182	7.16	112	4.41	7.7	3.5
1 1/2"	108	4.25	82.0	3.22	204	8.03	144	5.67	26.4	12.0
2"	108	4.25	82.0	3.22	230	9.05	163	6.42	27.5	12.5
3"	148	5.82	108.0	4.25	328	12.91	239	9.41	66.0	30.0
4"	185	7.28	127.0	5.00	403	15.86	285	11.22	132.2	60.0