

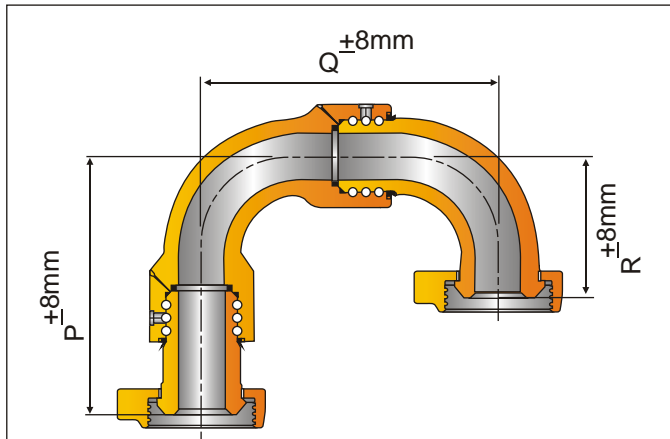

## LONG SWEEP SWIVEL JOINT (BASIC DIMENSIONS) STYLE-50



**STYLE - 50 LONG SWEEP SWIVEL JOINT**  
 END CONNECTION = UNION (M X M) FIG.602/1002/1502\*  
 MODEL:- PLSSJ - 50MM

SIZE	P (MM)	P (INCH)	Q (MM)	Q (INCH)	R (MM)	R (INCH)	WT. (LBSF)	WT. (KGF)
1"	214	8.42	188	7.40	115	4.52	24.0	10.88
1 1/2"	259	10.20	239	9.40	151	5.94	70.5	32.0
2"	277	10.90	272	10.70	156	6.14	73.0	33.0
3"	369	14.52	417	16.42	230	9.05	155.4	70.5
4"	452	17.80	539	21.22	310	12.20	335.0	152.0

\* FOR 2002 /2202 UNION ENDS CONSULT FACTORY

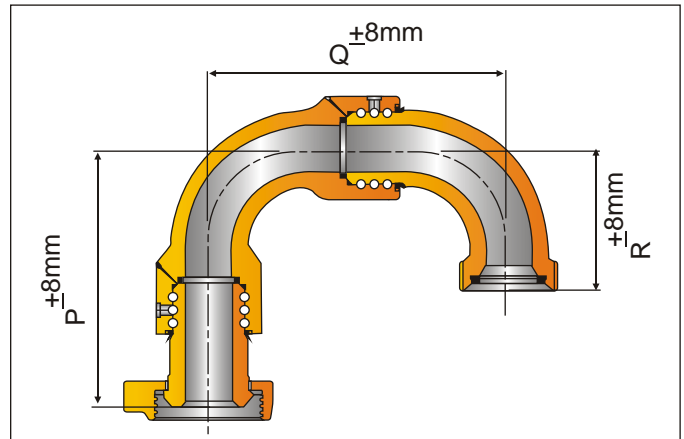

**STYLE - 50 LONG SWEEP SWIVEL JOINT**  
 END CONNECTION = UNION (M X F) FIG.602/1002/1502\*  
 MODEL:- PLSSJ - 50MF

SIZE	P (MM)	P (INCH)	Q (MM)	Q (INCH)	R (MM)	R (INCH)	WT. (LBSF)	WT. (KGF)
1"	214	8.42	188	7.40	111	4.37	19.84	9.00
1 1/2"	259	10.20	239	9.40	128	5.04	59.5	27.0
2"	277	10.90	272	10.70	145	5.70	62.0	28.0
3"	369	14.52	417	16.42	203	8.00	141.0	64.00
4"	452	17.80	539	21.22	247	9.72	291.0	132.0

\* FOR 2002 /2202 UNION ENDS CONSULT FACTORY

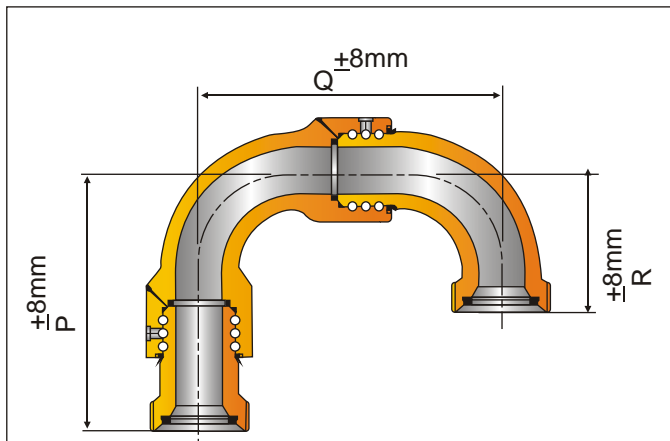

**STYLE - 50 LONG SWEEP SWIVEL JOINT**  
 END CONNECTION = UNION (F X F) FIG.602/1002/1502\*  
 MODEL:- PLSSJ - 50FF

SIZE	P (MM)	P (INCH)	Q (MM)	Q (INCH)	R (MM)	R (INCH)	WT. (LBSF)	WT. (KGF)
1"	214	8.42	188	7.40	111	4.37	16.0	7.1
1 1/2"	259	10.20	239	9.40	128	5.04	48.5	22.0
2"	277	10.90	272	10.70	145	5.70	51.0	23.1
3"	369	14.52	417	16.42	203	8.00	128.0	58.00
4"	452	17.80	539	21.22	247	9.72	247.0	112.0

\* FOR 2002 /2202 UNION ENDS CONSULT FACTORY

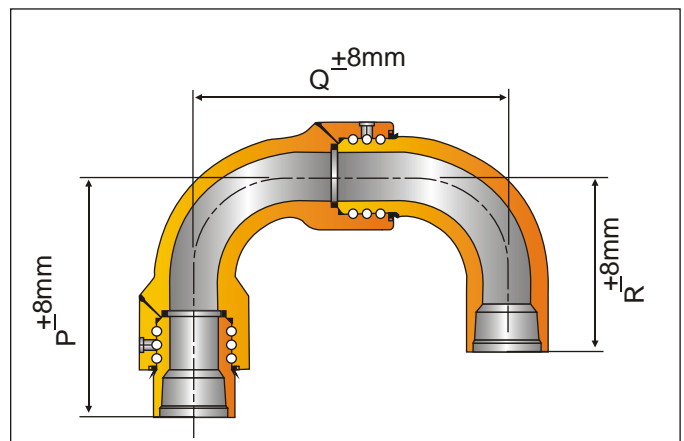

**STYLE - 50 LONG SWEEP SWIVEL JOINT**  
 END CONNECTION = THREADED  
 MODEL:- PLSSJ - 50T

SIZE	P (MM)	P (INCH)	Q (MM)	Q (INCH)	R (MM)	R (INCH)	WT. (LBSF)	WT. (KGF)
1"	182	7.16	188	7.40	112	4.41	13.2	6.0
1 1/2"	204	8.03	239	9.40	144	5.67	46.3	21.0
2"	230	9.06	272	10.70	163	6.42	48.5	22.0
3"	328	12.91	417	16.42	239	9.41	121.2	55.0
4"	403	15.86	539	21.22	285	11.22	240.3	109.0