

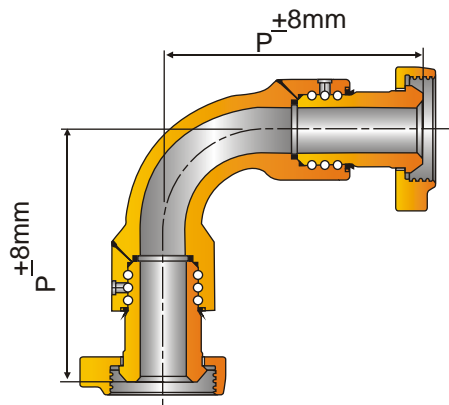

LONG SWEEP SWIVEL JOINT (BASIC DIMENSIONS) STYLE-60



STYLE - 60 LONG SWEEP SWIVEL JOINT
 END CONNECTION = UNION (M X M) FIG.602/1002/1502*
 MODEL:- PLSSJ - 60MM

SIZE	P (MM)	P (INCH)	WT. (LBSF)	WT. (KGF)
1"	214	8.42	23.4	10.6
1 1/2"	259	10.20	64.0	29.0
2"	277	10.90	67.0	30.4
3"	369	14.52	134.0	60.6
4"	452	17.80	288.0	130.6

* FOR 2002 /2202 UNION ENDS CONSULT FACTORY

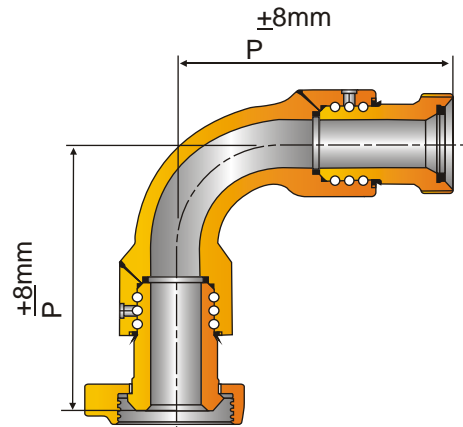

STYLE - 60 LONG SWEEP SWIVEL JOINT
 END CONNECTION = UNION (M X F) FIG.602/1002/1502*
 MODEL:- PLSSJ - 60MF

SIZE	P (MM)	P (INCH)	WT. (LBSF)	WT. (KGF)
1"	214	8.42	20.0	9.0
1 1/2"	259	10.20	51.0	23.20
2"	277	10.90	55.0	25.0
3"	369	14.52	121.2	55.0
4"	452	17.80	245.0	111.0

* FOR 2002 /2202 UNION ENDS CONSULT FACTORY

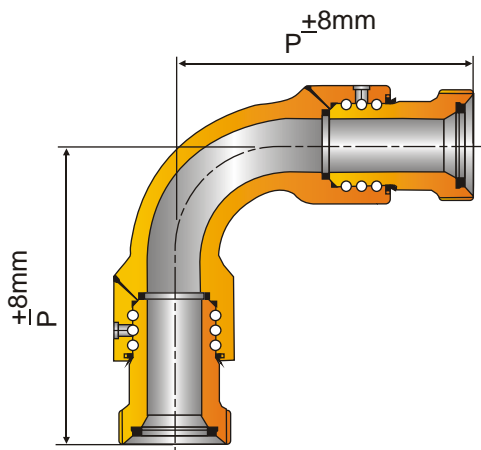

STYLE - 60 LONG SWEEP SWIVEL JOINT
 END CONNECTION = UNION (F X F) FIG.602/1002/1502*
 MODEL:- PLSSJ - 60FF

SIZE	P (MM)	P (INCH)	WT. (LBSF)	WT. (KGF)
1"	214	8.42	14.7	6.7
1 1/2"	259	10.20	42.0	19.0
2"	277	10.90	44.5	20.2
3"	369	14.52	108.0	49.0
4"	452	17.80	201.0	91.0

* FOR 2002 /2202 UNION ENDS CONSULT FACTORY

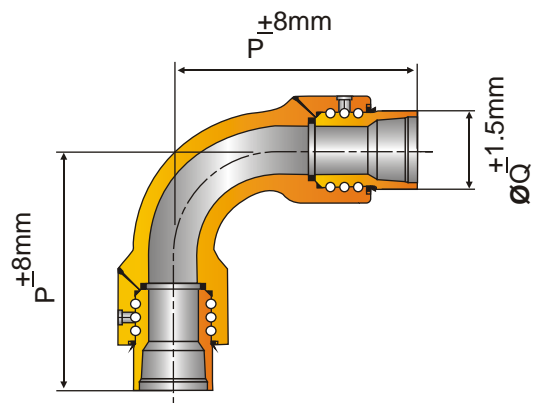

STYLE - 60 LONG SWEEP SWIVEL JOINT
 END CONNECTION = THREADED
 MODEL:- PLSSJ - 60T

SIZE	P (MM)	P (INCH)	Q (MM)	Q (INCH)	WT. (LBSF)	WT. (KGF)
1"	182	7.16	48.5	1.91	11.0	5.0
1 1/2"	204	8.03	82.0	3.22	35.2	16.0
2"	230	9.05	82.0	3.22	38.00	17.2
3"	328	12.91	108.0	4.25	93.00	42.10
4"	403	15.86	127.0	15.00	178.0	81.0