



## MUD VALVE

PARVEEN Mud Valves are Forged/Cast exclusively made for mud, cement, fracturing water and steam abrasive applications. All valves are hydrostatic shell and seat tested in accordance with the API 6A /API 6D Specifications. Valves are specially designed for oil-field applications like Well heads, Manifolds, Pipe line, Crude oil and Sour gas line, Well treating chemical, Drilling Chemical, water flood lines, abrasive drilling mud etc.

### Model - I

#### Features

- Designed specifically for abrasive and erosive use.
- Non directional seating and positive sealing between gate and seat.
- Easily replaceable of parts without any use of accessories.
- Can be supplied with flanged end ,hammer union end, threaded & butt weld end.
- Stainless and carbon steel insert with nitrite/viton elastomer in seat.
- Protected raising stem.
- Available from 2" to 4" with all temperature and pressure rating, services as per API - 6A.

Part No. & Weight				
FULL PORT		2"	3"	4"
FLANGED END	PART NO.	412-2065-00	412-3125-00	412-4065-00
	WT (LBS)	70	100	110
SCREWED END	PART NO.	412-4385-02	412-4805-02	412-4795-02
	WT (LBS)	48	53	61
WELD END	PART NO.	412-0025-03	412-0035-03	412-0045-03
	WT (LBS)	48	53	61

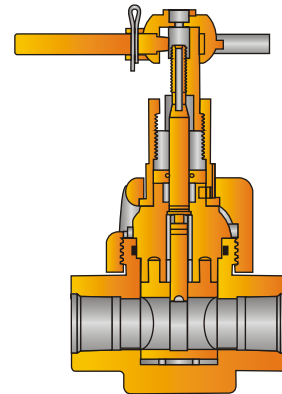

**Mud Valve (model - I)**

### Model - S

#### Features

- Designed for rigorous Oil-field services.
- Different end connection can be obtained without changing the main body or assembly.
- Through conduit with wear plate both size provide longer services.
- Heavy duty bearing at stem provides easy operation.
- Single gate stem.
- Available with all pressure and temperature class and services as per API-6A.

Part No. & Weight				
FULL PORT		2"	3"	4"
FLANGED END	PART NO.	412-2065-00	413-3125-00	413-4065-00
	WT (LBS)	125	254	384
SCREWED END	PART NO.	413-4385-02	413-4805-02	413-4795-02
	WT (LBS)	85	168	250
WELD END	PART NO.	413-0025-03	413-0035-03	413-0045-03
	WT (LBS)	87	170	252

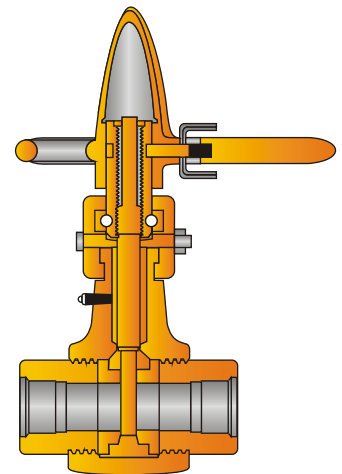

**Mud Valve (model - S)**