

LAYOUT FOR TESTING GAS CONDENSATE OR OIL WELLS

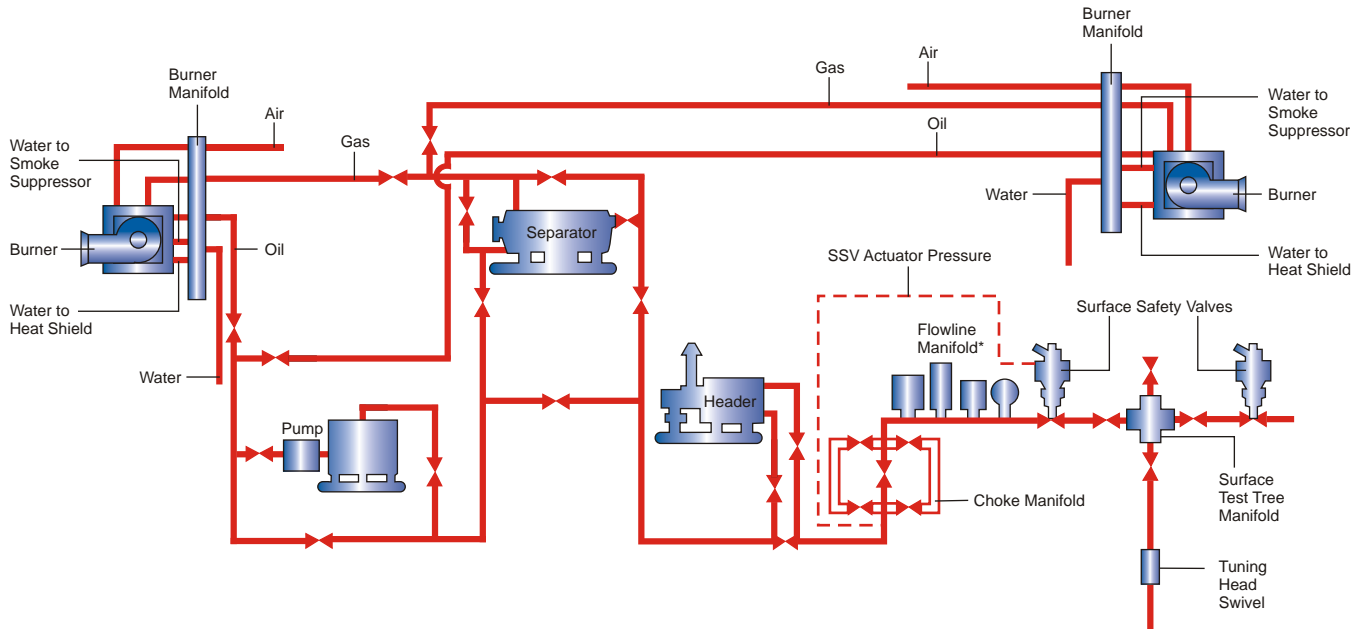

OBJECTIVES OF WELL TEST OPERATIONS

Following important data & samples to be obtained from well test :

- Gas production rate in MMSCF/D.
- Oil or Condensate production rate in barrels per day.
- B&W percentage of crude.
- Gravities of oil , gas & water
- Salinity of water with further compositional analysis if possible.
- Viscosity of condensate or crude.
- Pourpoint of condensate or crude, determined from fresh wellhead samples.
- Rough wellhead composition of produced gas, including H₂S, CO₂, CO&N₂ content.
- Bottom hole pressures, build-ups and draw-downs.
- Bottom hole temperature.
- Accurate recording of surface pressures, temperatures and flow data versus time.
- Separator gas samples, Oil samples , under pressure
- Bottom hole PVT samples.

Above introductory figure shows typical well testing layout for a very complete set of equipment. The equipment requirements and design for successful well testing obviously vary according to the specific requirement of operators.