

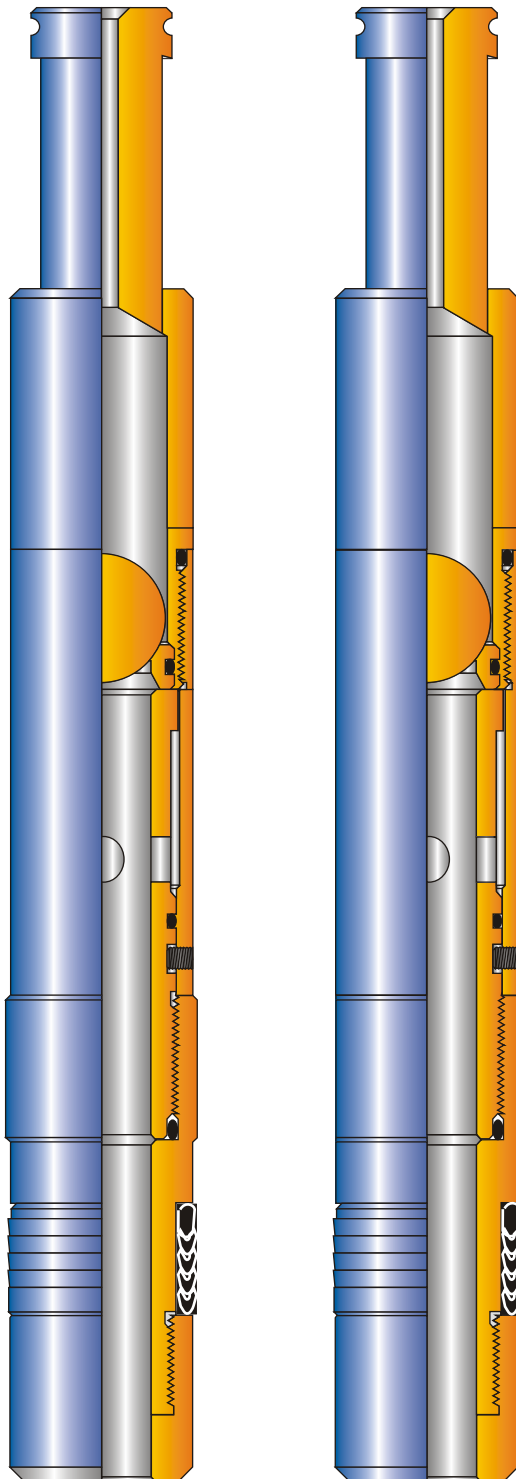

PARVEEN MODEL 'FB-2' AND 'RB-2' EQUALIZING CHECK VALVES



**MODEL
'FB-2'**

**MODEL
'RB-2'**

The Parveen Model 'FB-2' and 'RB-2' Equalizing Check Valves are complete equipment units, without any Locking Device. They are utilized in the following Tubing Mounted Equipment:

'FB-2'

**run in all Model 'F' Nipples and all Model
'L' Sliding Sleeves**

'RB-2'

**run in Bottom No-Go
'R' Nipples**

Both models are run into a Nipple Profile and hold pressure from above only. The 'FB-2' model lands on the top of a 'F' Nipple Profile seal bore. The 'RB-2' model seats on the Bottom No-Go Shoulder of a 'R' Nipple

A 'C-1' Running Tool is used to run both valve assemblies.

Both models can be equalized prior to retrieval, by shifting open the Equalizing Mandrel Ports. Standard Pulling Tool is utilized for retrieval of these valves.

The Parveen 'FB-2' and 'RB-2' Equalizing Check Valves are manufactured for Standard, H₂S and H₂S-CO₂ service.

Applications :

1. Can be used as a plug to pressure test tubing.
2. To set hydraulically actuated packer with the check valve positioned below the packer.
3. For gas lift operations.
4. To be used as a standing valve in wells which have downhole electric pumps.

Ordering information :

Please specify nipple model, seal bore size, check valve model, working pressure and temperature, percentage of H₂S and Co₂



PARVEEN MODEL 'FB-2' AND 'RB-2' EQUALIZING CHECK VALVES

'FB-2' EQUALIZING CHECK VALVE SPECIFICATIONS								
Tubing Nipple Accessory Availability			To Run			To Pull		Maximum Check Valve OD
Tubing Size	Nipple Size	Check Valve	'C-1' Running Tool	Jar Down Pulling Tool		Pulling Tool type		
ID-Inches	Seal Bore Inches	'FB-2' Size	Size Inches	OTIS	CAMCO	OTIS	CAMCO	
1.900	1.437	1.43	1.900			40RB14	JUC15174	1.490
	1.500	1.50		40SB6	JDC15154			1.552
2.1/16	1.562	1.56	2.1/16			40SB6	JDC15154	1.615
	1.625	1.62		1.672				
	1.781	1.78		1.865				
2.3/8	1.812	1.81	2.3/8	40SB1	JDC15169	40RB17	JUC15185	1.865
	1.875	1.87		40SB1	JDC15169	1.905		
2.7/8	2.250	2.25	2.7/8	40SB2	JDC15171	40RB18	JUC15189	2.302
	2.312	2.31		40SB2	JDC15179	2.364		
3.1/2	2.750	2.75	3.1/2	40SB9	JDC15181	40RB19	JUC15191	2.802
	2.812	2.81		40SB9	JDC15181	2.865		
	3.688	3.68		3.740				
4.1/2	3.750	3.75	4.1/2	40SB10	JDC15183	40RB20	JUC15193	3.802
	3.812	3.81		40SB10	JDC15183	3.875		

'RB-2' EQUALIZING CHECK VALVE SPECIFICATIONS								
Tubing Nipple Accessory Availability			To Run			To Pull		Maximum Check Valve OD
Tubing Size	Nipple Size	Check Valve	'C-1' Running Tool	Jar Down Pulling Tool		Pulling Tool type		
ID-Inches	Seal Bore Inches	'RB-2' Size	Size Inches	OTIS	CAMCO	OTIS	CAMCO	
1.900	1.437	1.43	1.900			40RB14	JUC15174	1.427
	1.500	1.50		40SB6	JDC15154			1.490
2.1/16	1.562	1.56	2.1/16			40SB6	JDC15154	1.552
	1.625	1.62		1.615				
	1.781	1.78		1.771				
2.3/8	1.812	1.81	2.3/8	40SB1	JDC15169	40RB17	JUC15185	1.802
	1.875	1.87		40SB1	JDC15169	1.865		
2.7/8	2.250	2.25	2.7/8	40SB2	JDC15171	40RB18	JUC15189	2.240
	2.312	2.31		40SB2	JDC15179	2.302		
3.1/2	2.750	2.75	3.1/2	40SB9	JDC15181	40RB19	JUC15191	2.740
	2.812	2.81		40SB9	JDC15181	2.802		
	3.688	3.68		40RB20	JUC15193	3.678		
4.1/2	3.812	3.81	4.1/2	40SB10	JDC15183	40SB10	JDC15183	3.802