



PARVEEN JUNK SUBS

Junk Subs - Description and Usage

PARVEEN Junk Subs capture and trap junk that is too heavy to circulate. They are designed to be used in the drill collar string just above the rock bit or milling tool. The tool consists of a steel mandrel with an oversized sleeve or "skirt" attached over the mandrel. The "skirt" will trap the large cutting and junk which are too heavy to be circulated out of the hole. The "skirt" is manufactured with bleed holes to allow the mud to drain once it is brought out of the hole. It is recommended that two Junk Subs be run in tandem to decrease the possibility of junk bypassing a single Junk Sub. The Junk Subs do not have welding on its body.

PARVEEN Junk Subs are used directly above the Mill or drilling bit for easy removal of cuttings. In hard milling jobs, two or three junk subs are run one after the other. This increases capacity to remove cuttings & provides additional stabilization to mill. PARVEEN's Junk subs can be run in both open hole & cased hole.

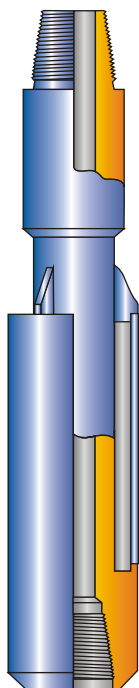

Standard Type Junk Sub

SPECIFICATIONS-PARVEEN JUNK SUBS						
MILL SIZE		4-1/4-4-5/8	4-5/8-4-7/8	5-1/8-5-7/8	6-6-3/8	6-1/2-7-1/2
O.D. OF CUP (IN)		3-11/16	4	4-1/2	5	5-1/2
TOP CONNECTION		2-3/8	2-7/8	3-1/2	3-1/2	3-1/2
PIN		REG.	REG.	REG.	REG.	REG.
10 INCH LONG CUP	PART NO.	8036800	8040810	8045820	8050820	8055820
	WEIGHT	55	63	80	83	97
20 INCH LONG CUP	PART NO.	8136800	8140810	8145820	8150820	8155820
	WEIGHT	65	87	105	120	136
30 INCH LONG CUP	PART NO.	8236800	8240810	8245820	8250820	8355820
	WEIGHT.	80	108	128	156	183

MILL SIZE		7-1/2-8-1/2	8-5/8-9-5/8	9-5/8-11-3/8	11-1/2-13
O.D. OF CUP (IN)		6-5/8	7	8-5/8	9-5/8
TOP CONNECTION		6-5/8	4-1/2	6-5/8	6-5/8
PIN		REG.	REG.	REG.	REG.
10 INCH LONG CUP	PART NO.	8066830	8070830	8086840	8096840
	WEIGHT	160	168	255	285
20 INCH LONG CUP	PART NO.	8166830	8170830	8186840	8186840
	WEIGHT	239	246	342	420
30 INCH LONG CUP	PART NO.	8266830	8270830	8286840	8286840
	WEIGHT.	289	302	430	530

HOW TO ORDER :

SPECIFY :

- 1) Name and Number of Assembly.
- 2) Connection size and Type, if other than Standard.



PARVEEN JUNK BASKETS

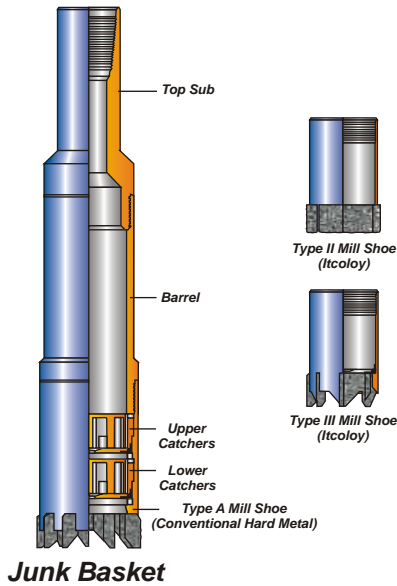

PARVEEN Junk Baskets are a junk fishing tool designed to give trouble free operation in rough oil field conditions.

This robust, field dressable tool is used to mill down over odd shaped fish into the formation, making a core and allowing the fish to enter the barrel.

When the Junk Basket is retracted the fingers break the core and bring with it the fish to the surface.

To remove the fish from the tool, simply break out the shoe and if fingers are damaged, redress with new catcher. Your tool is then ready for re-use.

SPECIFICATIONS-PARVEEN JUNK BASKETS

HOLE SIZE		3-3/4-4-1/8	4-1/4-4-1/2	4-5/8-5	5-1/8-5-1/2	5-5/8-6	6-1/8-6-1/2	6-5/8-7
O.D. BARREL (TOP END)		3-5/8	3-3/4	3-7/8	4-1/4	4-3/4	5-1/4	5-3/4
O.D. SHOE (TOP END)		3-5/8	4-1/16	4-1/2	4-7/8	5-3/8	5-7/8	6-1/4
MAX. DIAMETER OF FISH		2-23/32	2-31/32	3-3/8	3-23/32	4-1/16	4-1/2	4-13/16
COMPLETE ASSEMBLY	PART NO.	135-362XX	135-375XX	135-387XX	135-425XX	135-475XX	135-525XX	135-575XX
	WEIGHT	55	60	65	80	100	110	125

HOLE SIZE		7-1/4-8	8-1/4-9	9-1/4-10-1/8	10-1/4-11-5/8	11-3/4-12-1/2	12-5/8-15	15-20
O.D. BARREL (TOP END)		6-1/2	7-1/2	8-1/2	9-3/8	10-3/8	11-3/8	13-3/4
O.D. SHOE (TOP END)		7-1/8	8-1/8	9-1/8	10-1/8	11-1/4	12-1/4	14-1/4
MAX. DIAMETER OF FISH		5-7/16	6-3/16	7-3/16	8-1/16	9-1/16	10-1/16	12-1/16
COMPLETE ASSEMBLY	PART NO.	135-650XX	135-750XX	135-850XX	135-938XX	135-103XX	135-113XX	135-137XX
	WEIGHT	160	205	255	290	360	450	655

REPLACEMENT PARTS

PART	PART NO.	135-362-01	135-325-01	135-387-01	135-425-01	135-475-01	135-525-01	135-575-01
UPPER CATCHER	PART NO.	135-362-01	135-325-01	135-387-01	135-425-01	135-475-01	135-525-01	135-575-01
LOWER CATCHER	PART NO.	135-362-02	135-325-02	135-387-02	135-425-02	135-475-02	135-525-02	135-575-02
CONVENTIONAL SHOE	PART NO.	135-362-03	135-325-03	135-387-03	135-425-03	135-475-03	135-525-03	135-575-03
TOP SUB	PART NO.	135-362-04	135-325-04	135-387-04	135-425-04	135-475-04	135-525-04	135-575-04
BARREL	PART NO.	135-362-05	135-325-05	135-387-05	135-425-05	135-475-05	135-525-05	135-575-05
TYPE II MILL SHOE	PART NO.	135-362-06	135-325-06	135-387-06	135-425-06	135-475-06	135-525-06	135-575-06
TYPE III MILL SHOE	PART NO.	135-362-07	135-325-07	135-387-07	135-425-07	135-475-07	135-525-07	135-575-07

PART	PART NO.	135-650-01	135-750-01	135-850-01	135-938-01	135-103-01	135-113-01	135-137-01
UPPER CATCHER	PART NO.	135-650-01	135-750-01	135-850-01	135-938-01	135-103-01	135-113-01	135-137-01
LOWER CATCHER	PART NO.	135-650-02	135-750-02	135-850-02	135-938-02	135-103-02	135-113-02	135-137-02
CONVENTIONAL SHOE	PART NO.	135-650-03	135-750-03	135-850-03	135-938-03	135-103-03	135-113-03	135-137-03
TOP SUB	PART NO.	135-650-04	135-750-04	135-850-04	135-938-04	135-103-04	135-113-04	135-137-04
BARREL	PART NO.	135-650-05	135-750-05	135-850-05	135-938-05	135-103-05	135-113-05	135-137-05
TYPE II MILL SHOE	PART NO.	135-650-06	135-750-06	135-850-06	135-938-06	135-103-06	135-113-06	135-137-06
TYPE III MILL SHOE	PART NO.	135-650-07	135-750-07	135-850-07	135-938-07	135-103-07	135-113-07	135-137-07



PARVEEN REVERSE CIRCULATING JUNK BASKETS

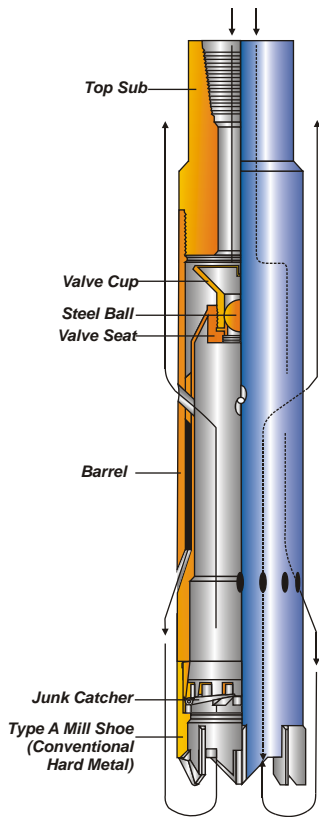

PARVEEN's Reverse Circulating Junk Baskets are designed to catch effectively small Junk objects, by utilizing the principal of Reverse Circulation principle. These Junk objects are successfully deflected into the Junk Basket and returned which would otherwise cannot be fished out by other Junk Baskets. This is used to retrieve all types of Junk accumulated at the bottom of the well. The reverse circulation feature ensures complete recovery of Junk. PARVEEN's design ensures drain thru the tool which eliminates the possibilities of pulling a wet string even though inner barrel is plugged by the core.

CONSTRUCTION: This consists of a barrel, a top sub, valve cup, steel ball and a ball seat, junk catcher and Milling Shoe. For ease of handling a Junk Basket, a lifting sub is provided.

Barrel is a two bowl assembly, with the steel ball in place, the circulation fluid goes around the ball thru the inner passage of the barrel, is jetted out and downward thru the lower parts of the barrel, flows in a continuous stream into the barrel, up thru the barrel then goes out of the return part at the upper end of the barrel. With this reverse circulation all the Junk which is collected from the bottom, falls in the Junk Catcher.

USAGE: PARVEEN's Reverse Circulating Junk Basket retrieves all type of Junk such as bearing, broken slips, various hand tools, slivers, bit sizes of wirelines, rock bit cones, debris from twisted off drill strings, milling cuttings and so on.

SPECIFICATIONS-PARVEEN JUNK BASKETS

HOLE SIZE		3-3/4-4	4-1/8-4-1/2	4-5/8-5	5-1/8-5-1/2	5-5/8-6	6-1/8-6-1/2	6-5/8-7-3/8
O.D. (IN)		3-5/8	4	4-1/2	4-7/8	5-1/8	5-3/4	6-1/4
MAX. DIA. OF FISH (IN)		2-11/32	2-17/32	3-1/16	3-9/16	3-3/4	4-13/32	4-3/4
NO. OF TEETH ON MILL		6	6	8	8	8	8	8
COMPLETE ASSEMBLY	PART NO.	8636801	8640801	8645811	8648811	8637821	867821	8647821
	WEIGHT	85	98	108	128	142	185	238

HOLE SIZE		7-1/2-8-1/4	8-3/8-9-1/2	9-5/8-10-5/8	10-3/4-11-5/8	11-3/4-12-1/2	12-5/8-13-5/8	13-3/4-16
O.D. (IN)		7	7-7/8	9-1/8	10-1/8	11	11-7/8	13
MAX. DIA. OF FISH (IN)		5-3/16	6-1/16	7-1/16	7-11/16	8-5/16	8-11/16	9-7/8
NO. OF TEETH ON MILL		8	8	10	10	12	12	14
COMPLETE ASSEMBLY	PART NO.	8670831	8678831	8691841	8601841	8610841	8618841	8630841
	WEIGHT	293	374	441	576	665	797	932

HOW TO ORDER :

SPECIFY :

- 1) Name and Number of Assembly.
- 2) O.D. And type of shoe.
- 3) Top Connection and Type, if other than Standard.

AVAILABLE ACCESSORIES : Finger Shoes, Magnet Inserts.